



HI6221
**Advanced pH and ORP
Benchtop Meter**

Dear Customer,

Thank you for choosing a Hanna Instruments® product.

Please read this instruction manual carefully before using this instrument as it provides the necessary information for correct use of this instrument, as well as a precise idea of its versatility.

If you need additional technical information, do not hesitate to e-mail us at tech@hannainst.com.

Visit www.hannainst.com for more information about Hanna Instruments and our products.

This manual has been written for **HI6221** Advanced pH and ORP Benchtop Meter with software version 2.00 and higher. Software version 2.00 and higher is security compliant with **EU RED article 3.3 (d)(e)**.

TABLE OF CONTENTS

1. Preliminary Examination	3	9.5. Alarms	54
2. Safety Measures	4	9.6. Logging	55
3. User Interface – Icons	5	9.7. Profiles	58
4. General Description & Intended Use	7	10. Calibration Procedure	59
4.1. Main Features	8	10.1. pH Calibration	59
5. Specifications	9	10.2. Relative mV Calibration	63
5.1. Instrument	9	10.3. Calibration with Millesimal Buffers	65
5.2. Electrodes	11	10.4. Calibration Messages	65
6. Functional & LCD Description	12	11. Measurement	66
6.1. Main Unit	12	11.1. Measurement Tips	66
6.2. Electrodes	14	11.2. Direct Readings	67
7. Getting Started	15	11.3. Direct / Autohold Readings	67
7.1. Attaching the Electrode Arm	15	12. Logging	68
7.2. Using the Electrode Holder	16	12.1. Automatic Logging	68
7.3. Connecting the Electrodes, Keyboard, Printer	16	12.2. Manual Logging	69
7.4. Powering the Unit, Selecting Operating Language & Regional Preferences	17	12.3. Autohold Logging	70
7.5. Basic Operations	19	13. Maintenance & Conditioning	71
8. System Menu Items	19	13.1. Meter	71
8.1. Users	20	13.2. HI1131B pH Electrode	71
8.2. System Settings	23	13.3. HI7662-TW Temperature Probe	72
8.3. Measurement Settings	34	14. Software Update	73
8.4. Log Recall	37	15. Error Messages	74
8.5. Help	44	16. Accessories	75
9. Measurement & Electrode Setup Menu	45	17. Abbreviations	81
9.1. Calibration	45	Certification	82
9.2. Reading	47	Recommendations for Users	82
9.3. Temperature	49	Warranty	82
9.4. View	51	Regulatory Notices for the Wi-Fi Module	83

All rights are reserved. Reproduction in whole or in part is prohibited without the written consent of the copyright owner, Hanna Instruments Inc., Woonscket, Rhode Island, 02895, USA. Hanna Instruments reserves the right to modify the design, construction, or appearance of its products without advance notice.

1. PRELIMINARY EXAMINATION

The [HI6221](#) is Hanna Instruments® advanced pH and ORP meter with a large touch screen display and streamlined design.

Package contents

Each [HI6221](#) is supplied with:

- [HI1131B](#) pH electrode
- [HI7662-TW](#) temperature probe
- pH calibration starter kit consisting of:
 - pH 4.01 buffer solution (2 sachets)
 - pH 7.01 buffer solution sachet (4 sachets)
 - pH 10.01 buffer solution sachet (2 sachets)
- [HI700601](#) electrode cleaning solution sachet (2 sachets)
- [HI70300S](#) storage solution for pH & ORP electrodes (25 mL)
- [HI7082](#) 3.5M KCl electrolyte solution (30 mL)
- [HI764060](#) electrode holder with following accessories:
 - base plate (integrated pivot pin) and screw, requires installation
 - cable holder clip, attached
 - electrode holder with adapter, attached
- Capillary pipette
- 24 VDC power adapter
- USB-C to USB-A cable
- Probe quality certificate
- Quick reference guide with instrument quality certificate

For **ORP** (redox) measurements a separate sensor is required.

See [16. Accessories](#) section for available ORP models.

Note: *Save all packing material until you are sure the instrument works correctly. Any damaged or defective item must be returned in its original packing material with the supplied accessories.*

Ordering information [HI6221](#)-01 US power plug
 [HI6221](#)-02 EU power plug

2. SAFETY MEASURES



Handling and usage precautions

The unit, while not fragile, can be damaged by improper handling and usage.

- Transport the unit with all cables removed.
- Keep the unit on a stable and even surface, away from contact with liquid.
- Avoid excessive dirt and dust.
- Protect the unit from contact with food, oils, and chemicals.
- If the device becomes wet, gently wipe the exterior with a clean, dry cloth.
- Keep away from direct sunlight.
- Use in a safe place that is appropriate to application requirements.
- Use attachments and accessories specified in this manual only.
- Operate the capacitive touchscreen and buttons without applying pressure.
- Do not puncture the capacitive touchscreen or drop the unit.
- Do not use the device near heat sources.
- Do not place objects on top of the device.
- Do not insert objects into the ports, spaces around keys, other than the intended cable, USB drive.



Battery safety





The coin-cell battery is replaceable by a professional service center only.



 WARNING	
<ul style="list-style-type: none"> • INGESTION HAZARD: This product contains a button cell or coin battery. • DEATH or serious injury can occur if digested. • A swallowed button cell or coin battery can cause Internal Chemical Burns in as little as 2 hours. • KEEP new and used batteries OUT OF REACH OF CHILDREN. • Seek immediate medical attention if a battery is suspected to be swallowed or inserted inside any part of the body. 	







- Remove and immediately recycle or dispose of used batteries according to local regulations and keep away from children. Do NOT dispose of batteries in household trash or incinerate.
- Even used batteries may cause severe injury or death.
- Call a local poison control center for treatment information.
- Coin-cell battery type CR2032
- Nominal voltage 3.0 V
- Non-rechargeable batteries are not to be recharged.
- Do not force discharge, recharge, disassemble, heat above 85 °C (185 °F) or incinerate. Doing so may result in injury due to venting, leakage or explosion resulting in chemical burns.
- Ensure the batteries are installed correctly according to polarity (+ and -).
- Do not mix old and new batteries, different brands or types of batteries, such as alkaline, carbon-zinc, or rechargeable batteries.
- Remove and immediately recycle or dispose of batteries from equipment not used for an extended period of time according to local regulations.
- Always completely secure the battery compartment. If the battery compartment does not close securely, stop using the product, remove the batteries, and keep them away from children.









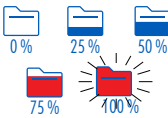









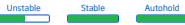





3. USER INTERFACE – ICONS

Capacitive Keys	Description
	Back – return to a previous hierarchical menu level
	Home – access to measurement screen
	Menu – access to the main menu

Main Menu	Description
	Users – login and rights configuration; instrument accessibility
	System Settings – system configuration, connectivity & printing items
	Measurement Settings
	Log Recall – access logged data
	Help – access support

Measurement	Description
	Measurement Menu, accessed from measurement screen
	pH electrode
	Warning on standby / active function

Logging	Description
	Start / Stop logging Current index, displayed above Time since log start, displayed below
	Manual logging Current index, displayed above
	Triggers log session, pending next stable measurement
	Autohold logging in progress
	Autohold applied
	Autohold, waiting stable pH/mV measurement
	Annotated text/Annotated text in use
	Used storage capacity (at full capacity the icon is displayed blinking)

		Description	
Log recall	 / 	Table view, function active/not selected	
	 / 	Graph view, function active/not selected	
	 / 	Information view, function active/not selected	
General		Measurement profile	
		Background operation in progress	
		Alarm enabled	
		Stability/Autohold indicator	
		Active buffer selection during calibration	
		Forward/backward navigation, sequence of steps	
		Gray icon > function not available	
Connectivity & Printing		Description	
	Ethernet		Connection established (tap for IP address)
			Connection in progress
			Connection error
	Wi-Fi		Connection established (tap for IP address)
			Connection in progress
			Connection error
	USB		USB-A or USB-C flash drive plugged in
			High-power consumption with the flash drive plugged in
	PC		PC connection established through USB-C port
Printer		Printer connected - printing manual log option enabled	
		Printer connected - printing manual log option disabled	
		Printer not recognized or printing error	

4. GENERAL DESCRIPTION & INTENDED USE

The [HI6221](#) is Hanna Instruments® advanced benchtop meter with a capacitive display, comprised of a housing and an integrated pH/ORP measurement module.

Compact and easy to operate, the meter is delivered with Hanna Instruments [HI1131B](#) combination pH electrode and [HI7662-TW](#) temperature probe for pH measurement.

A separate ORP sensor is required for ORP measurements.

[HI1131B](#) is a glass body, double junction, refillable pH electrode with an indicating sensor made of high temperature (HT) glass. The double junction reference and HT glass design allow the [HI1131B](#) to be used in a wide variety of applications.

Probe connection to the unit is secured through a galvanically isolated BNC connection.

[HI7662-TW](#) stainless steel temperature probe allows the meter to perform automatic temperature compensation (ATC).

This system responds to a complex range of measurement and monitoring requirements, providing accuracy, reproducibility, and reliability.

[HI6221](#) is supplied with an electrode holder that has a flexible arm. The holder can be mounted quickly and provides secure support for electrodes while taking measurements in sample containers.

The user can select between five different views.

- Basic measurement configuration
- Simple GLP with calibration information
- Full GLP with electrode status and calibration point details (pH only)
- Live updated, interactive graph
- Tabulated data with date, time, and notes

Capacitive touch screen with multi-touch support

The benchtop unit has a 7-inch color display with 800 x 480p resolution.

The capacitive, multi-touch screen supports video playback and data plotting.

4.1. MAIN FEATURES

Measurement & Calibration

- Measure
 - › pH/mV (pH) with temperature
 - › mV/Rel.mV (ORP) with temperature
- Application-specific profiles allow quick and direct measurement without the need to update the sensor and system settings
- Measurement stability indicator (using the Stability Criteria setting)
- Reading modes: direct and direct/autohold
- pH temperature compensation can be Automatic (using temperature probe) or set manually
- Audible and/or alarm messages for measurements outside predefined limits
- Galvanic isolation for pH/ORP measurement module
- 5-point pH calibration with automatic recognition for standard buffers (Hanna and NIST buffers)
- Choice of standard or custom buffers for calibration
- Non-volatile memory saves data and settings

Logging

- Active log during measurement
- Log collection of up to 255 MB of data points (with time and date stamp)
- Logging types: manual, automatic, autohold
- Sample ID for manual and autohold data

Connectivity features & services

- Transfer logged data to a USB thumb drive
- Log files include measurements and calibration data (as .CSV file)
- FTP and email for log export via Ethernet and Wi-Fi connection
- Download logs using the benchtop's embedded web server
- USB type A for USB drive, printer, and keyboard
- USB type C for USB drive and PC connection

User-support feature

- Help section — brief overview of instrument's main functionalities and features

5. SPECIFICATIONS

5.1. INSTRUMENT

pH	Range*	–2.0 to 20.0 pH –2.00 to 20.00 pH –2.000 to 20.000 pH
	Resolution	0.1 pH 0.01 pH 0.001 pH
	Accuracy	±0.1 pH ±0.01 pH ±0.002 pH (±1 last significant digit)
mV	Range	–2000.0 mV to 2000.0 mV
	Resolution	1 mV 0.1 mV
	Accuracy	±0.2 mV ±1 last significant digit
Temperature	Range	–20.0 to 120.0 °C –4.0 to 248.0 °F 253.2 to 393.2 K
	Resolution	0.1 °C / 0.1 °F / 0.1 K
	Accuracy	±0.2 °C / ±0.4 °F / ±0.2 K
Relative mV offset	Range	±2000.0 mV
Reading	Modes	Direct Direct/Autohold
	Stability criteria	Accurate Medium Fast
	Isopotential	–2.000 to 20.000 pH
pH calibration	Calibration points	Up to 5
	Type	Automatic Semiautomatic Manual
	Standard buffers	Hanna and NIST pH 1.68, 3.00, 4.01, 6.86, 7.01, 9.18, 10.01, 12.45
	Custom buffers	Up to 5
	Custom group	Up to 5
	1 st calibration point	Offset or Points (user setting)
	Reminder	Daily: 0 min. to 23 hours and 59 min. Periodic: 1 min. to 30 days, 23 hours and 59 min. Disabled

* The range may be limited by the probe's limits.

Temperature user calibration		1 point, adjustable
pH views	Basic	Measurement pH: pH measurement and pH mV mV: measurement Rel.mV: measurement, Absolute mV Temperature (ATC or MTC) Measurement profile (when enabled) Stability status
	Simple GLP	Basic view information pH last calibration date, electrode offset, average slope, and electrode condition (for 24 hours after calibration) Rel. mV: Last Calibration, Offset
	Full GLP (pH only)	Simple GLP information and calibration point details
	Graph (Plot)	pH, mV, Rel. mV and temperature versus time graph can be panned or zoomed (pinch-to-zoom technology)
	Table	Measurements updated every second are displayed in table. With Manual logging type, configuration displays table of logged data points.
pH temperature compensation		Automatic or Manual
Logging	Type	Automatic Manual Autohold
	Number of records	50 000 maximum per file Stores at least 1 000 000 data points per user
	Automatic interval	1, 2, 5, 10, 30 seconds 1, 2, 5, 10, 15, 30, 60, 120, 150, 180 minutes
	Sample ID	Incremental mode or manual
	Export option	.CSV file format
Audit log		.CSV file format export (Admin user only)
Users		Up to 9 users and the default administrator account
Connectivity	USB-A	2 ports for keyboard and/or printer input or USB thumb drive
	USB-C	1 port for PC connectivity and USB-C type thumb drive
	Wi-Fi & Ethernet	FTP Web server Log transfer and download Email
	RS232	Connecting peripherals
Power supply		DC adapter 100-240 VAC to 24 VDC 2 A
Environment		0 - 50 °C / 32 - 122 °F / 273 - 323 K maximum 95 % RH non-condensing
Dimensions		205 x 160 x 77 mm (8.0 x 6.2 x 3.0 ")
Weight		Approximately 1.2 kg (26.5 lbs.)

5.2. ELECTRODES

HI1131B – pH electrode

Range	0 to 13 pH
Reference cell type	Double, Ag/AgCl
Junction type	Ceramic Single 15-20 μ L per h
Refill electrolyte	3.5M KCl
Maximum pressure	0.1 bar
Body material	Glass
Tip shape	Spheric (\emptyset 9.5 mm)
Operating temperature	-5 to 100 °C (23 to 212°F) – HT
Temperature sensor	No
Amplifier	No
Cable	Coaxial 1 m (3.3')
Recommended use	Laboratory samples, general purpose

HI7662-TW – Temperature probe

Body material	Stainless steel
Connector type	RCA Phono connector
Dimensions	Total length: 100 mm (3.94 ") Active part: \emptyset 3 mm (0.12 ")
Cable	1 m (3.3') length

6. FUNCTIONAL & LCD DESCRIPTION

6.1. MAIN UNIT

Front View

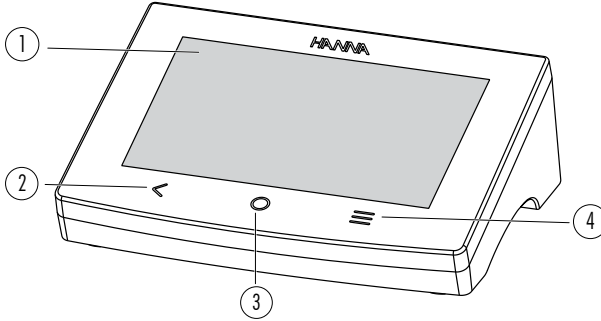

1. LCD display	3. Home key
2. Back key	4. Menu key

LCD Description

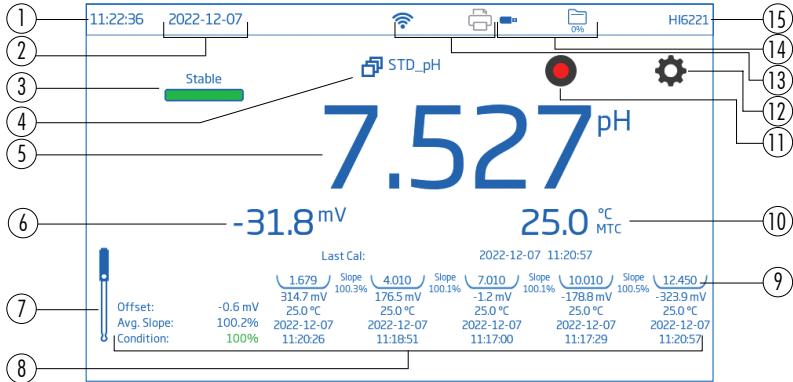

1. Current time	9. Buffer trays
2. Current date	10. Temperature reading and temperature compensation status
3. Stability indicator	11. Start logging icon
4. Measurement profile	12. Measurement settings icon
5. pH reading	13. Connectivity and Printer icons
6. pH mV reading	14. USB connection status
7. pH electrode icon	Used logging space
8. Calibration information	15. User name

Status Area



Continuously displayed after powering the unit, status area runs horizontally across the top of the LCD screen.

- 1. Current time and date
- 2. Network and device connectivity
- 3. Used storage capacity
- 4. User name

Tap on the status icons to view network details (📶) and used storage space (📁 0%).

Direct Keys

Icon	Name	Function
<	Back	<ul style="list-style-type: none"> • returns user to previous hierarchical menu level • exit or escape function
○	Home	<ul style="list-style-type: none"> • access to measurement screen • exit or escape function
☰	Menu	<ul style="list-style-type: none"> • access to Users, System Settings, Measurement Settings, Log Recall, Help

Rear View

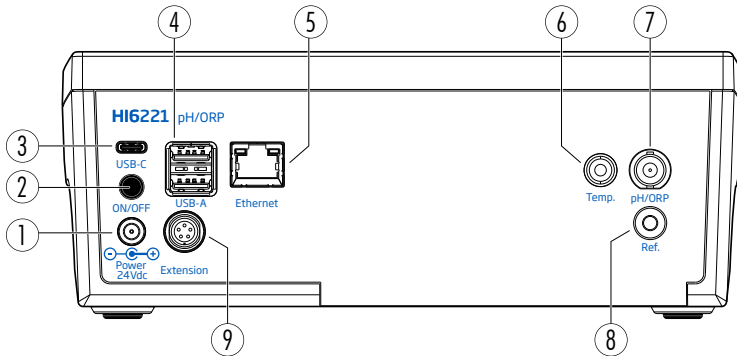

- 1. Input for power cable
- 2. Power button
- 3. Input for USB-C flash drive or PC cable
- 4. Input for USB-A flash drive (x2) or keyboard/printer
- 5. Ethernet port
- 6. Temperature probe connection port
- 7. pH/ORP probe connection port
- 8. Reference electrode socket
- 9. Peripherals port

6.2. ELECTRODES

HI1131B
pH electrode

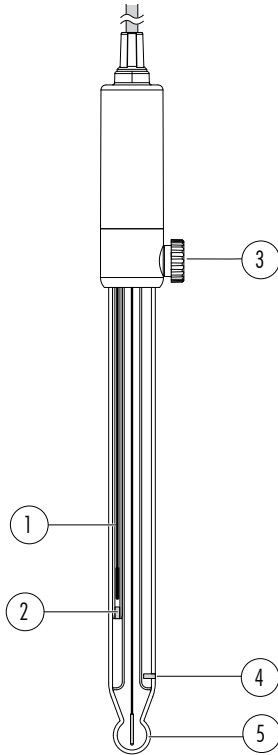

-
1. Reference wire
 2. Inner reference junction
 3. Reference fill cap
 4. Outer reference junction
 5. Glass bulb
-

HI7662-TW
Temperature probe

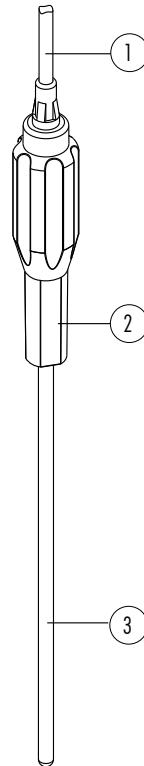

-
1. Cable
 2. Handle
 3. Stainless steel tube
-

7. GETTING STARTED

7.1. ATTACHING THE ELECTRODE ARM

Attaching the electrode holder base plate

- Take the [HI764060](#) electrode arm from the box.
- Identify the metal base plate (4) with the integrated pivot pin (5) and the screw (2).
The plate may be attached to either side of the meter, left (L) or right (R).
- Place the meter face down on a clean, dry surface.
- Align the hole on the base plate (3) over the rubber foot (6R or 6L).
- The pivot pin (5) should be facing downward.
- Use a screwdriver (1) to tighten the screw (2) and attach the base plate to the meter.
- Position the meter with the display facing up.
- Slide the electrode holder (7) over the pivot pin (5). A “slide in” motion is required to lock the arm into position.
- For increased arm rigidity, tighten the metal knobs on both sides of the electrode arm.

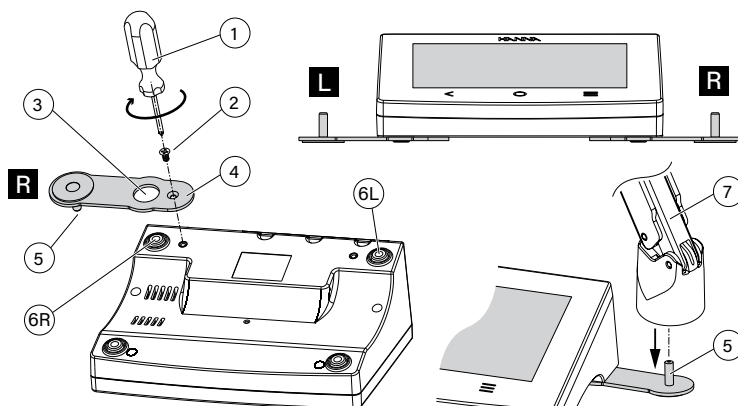

Cable holder clip

The electrode holder is delivered with a cable holder clip (attached) that secures several cables whilst allowing them to move freely with the arm motion.

1. To open the latch, press the clip inward while pulling up the latch.
2. To close the latch, lower latch over cable and snap closed.

The latch snaps in position and secures the cables inside.

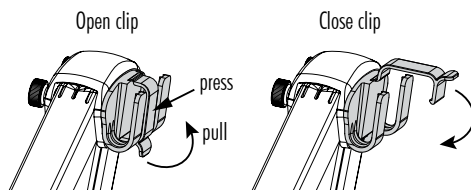

Reattach the cable holder clip onto the electrode arm.

1. Align the clip's dovetail over the slot.
2. Gently push down to slide in position.

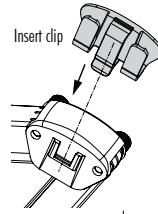

Using the adapter

The electrode arm ends with an electrode holder fitted with an adapter with three different-sized apertures:

- center-front (temperature probe only)
- center-back (adapter for pH or ORP probe)
- left and right (pH or ORP probe)

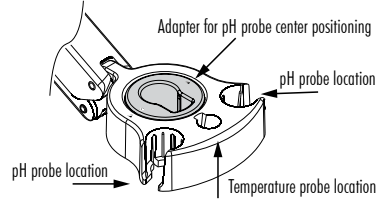

7.2. USING THE ELECTRODE HOLDER

Use the holder for electrode support and easy movement in and out of beakers and containers during calibration and sample measurement.

7.3. CONNECTING THE ELECTRODES, KEYBOARD, PRINTER

HI6221 Electrode compatibility

- Analog pH or ORP electrode with BNC connector (non-amplified or non-digital)
- pH or ORP half-cell sensors and separate reference electrodes with suitable jack connectors
- Hanna Instruments® pH electrodes with integral temperature elements.

Note: Always turn the meter off before connecting the electrode/probe!

Connecting the electrodes

HI1131B pH electrode is connected to the meter through a BNC connector, which makes attaching and removing the electrode an easy process. When connected, the electrode is automatically detected.

- Connect the electrode to the BNC connection port.
- Align the key and twist the plug into the socket.
- Place the probe into the holder and secure the cable. Power the unit.

Note: ORP electrodes utilize the BNC connection.

HI7662-TW temperature probe attaches to the meter through a RCA connector.

- Plug the connector into the socket.
- Place the probe into the holder and secure the cable. Power the unit.

Note: Ensure connectors and plugs are correctly plugged in prior to operating the device.

- Connect a pH or an ORP half cell to the BNC connector.
- Connect a reference half-cell electrode to the socket labeled **Ref**.

A banana connector is required for a separate reference.

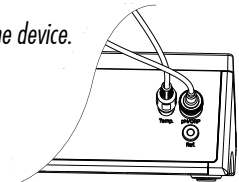

Connecting a USB-A keyboard

Connect a USB's keyboard plug into the USB-A input on the back of the unit.

Once connected the keyboard is automatically detected.

Use the keyboard to input user details, type passwords and enter sample information.

Connecting a printer

Hanna[®] aims to ensure meter compatibility with USB printers but can not ensure compatibility with all models.

HI6221 can print directly to certain models of USB-dedicated printers with PCL printer language capability.

Printer components and requirements

- Printer, PCL driver compatible
- Power cable
- USB connector cable with two ends:
 - › type B connector (plugs into printer)
 - › type A connector (plugs into the USB port on the meter)

Note: Meter must be correctly plugged in to power supply.

7.4. POWERING THE UNIT, SELECTING OPERATING LANGUAGE & REGIONAL PREFERENCES

1. Connect the power adapter to the rear panel of the meter.
2. Connect the power plug into the 24V power socket.
3. Press the black ON/OFF power button.

At start up, the meter briefly displays the initialization screen.

4. The instrument launches into a startup Tutorial. By default English is selected.

Use the language window (A) to select operating language.

5. Use the left and right arrow keys (D) to view the startup tutorial.

Alternatively tap **Skip** (B) to return to measurement.

See section [8.1. Users](#) for a more detailed description.

6. Use the slider icon (C) to disable the start up tutorial.

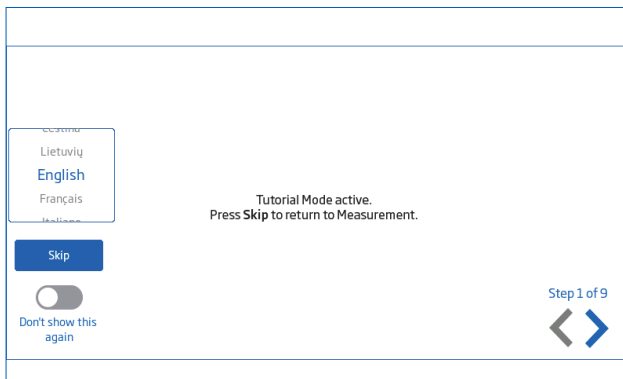

Note: Remove the transparent film that protects the capacitive touchscreen prior to operating the meter.

Create a New Admin Password

- Tap to select Admin.
- An “Unsecure Password” error message indicates that the current password isn’t strong enough and must be changed before signing in.
- Tap **OK** then use the on-screen keypad to enter a new password with a minimum of 8 characters.

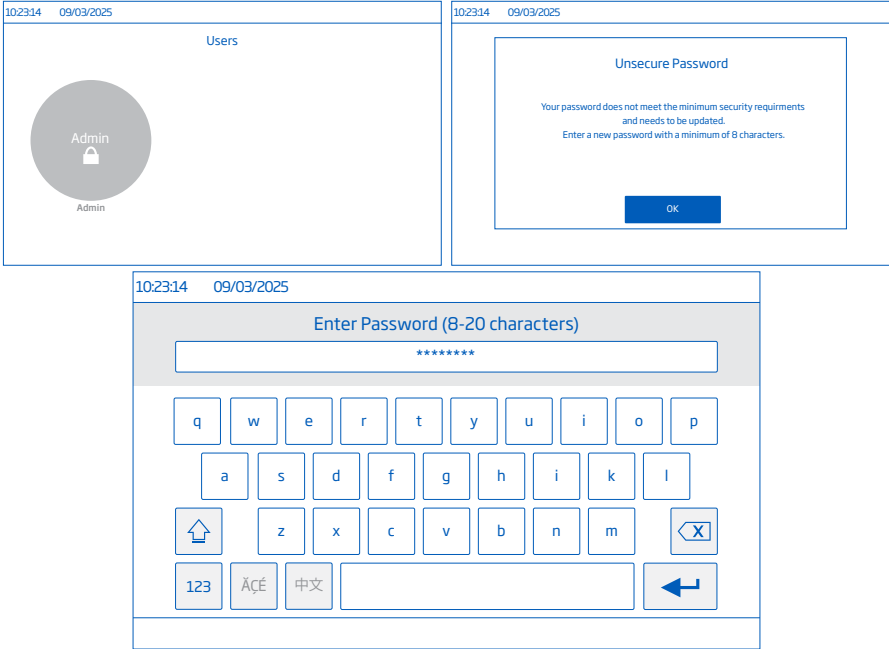



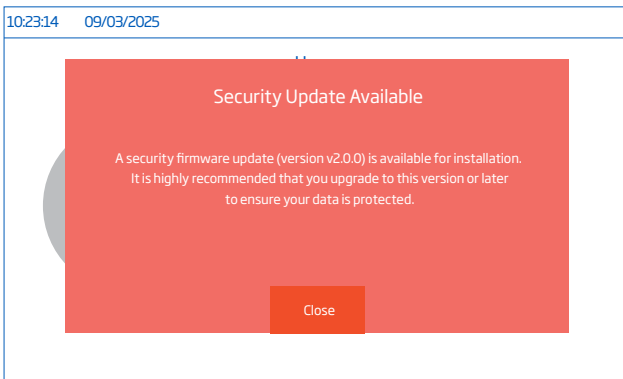





Note: Users are required to update their firmware whenever a security update becomes available. A message will be displayed on the screen. To check for new releases, scan the QR code or go to <https://software.hannainst.com>.



7.5. BASIC OPERATIONS

General operating modes are setup, measurement, logging, and data sharing.





- Tap  key (**Menu**) to access:
 -  User settings
 -  System settings
 -  Measurement settings
 -  Log recall files and file management.
User can view a single sample or an interval log session, see [9.6. Logging](#) section for detailed description.
 -  Help for text and video support
- Tap  key (**Home**) to return to measurement.
- Tap  icon (Measurement Menu) to access sensor-related functions.

8. SYSTEM MENU ITEMS

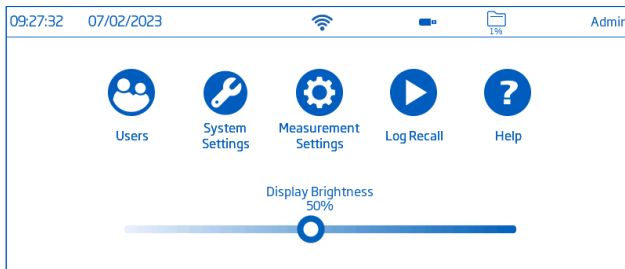
Tap  key (**Menu**) to access System Menu screen.

Note: In order to access the system menu a user must be logged in.



Symbol	Name	Functionality
	Users	Login and rights configuration & instrument accessibility
	System Settings	System configuration, connectivity and printing items
	Measurement Settings	Configure sensor-related functions
	Log Recall	Access logged measurement data
	Help	Access video-supported outline of main instrument functionalities

Brightness control bar



Drag the slider along the control bar to adjust brightness.

8.1. USERS

Users is the first item under the System Menu and enables logins and account creation.

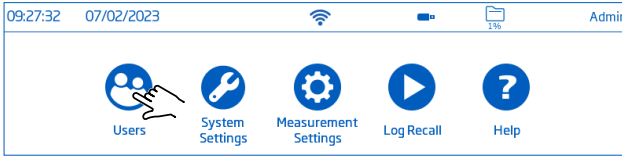

Default options are updated from the Users menu.

Function	Administrator Rights	Standard User
Enable account creation	✓	—
Reset password	✓	—
Delete account	✓	—
Factory settings reset	✓	—
Customize settings	✓	✓
Add FTP information	✓	✓
Change password	✓	✓
View and delete log files	✓	✓
Access and export audit logs	✓	—
Install TLS/SSL certificates	✓	✓

Account Management

1. Log in to the Administrator account.
2. Tap **Edit Users** to enter the Account Management screen.

The administrator can:

- Enable Account Creation
- Reset password for user accounts
- Delete user accounts

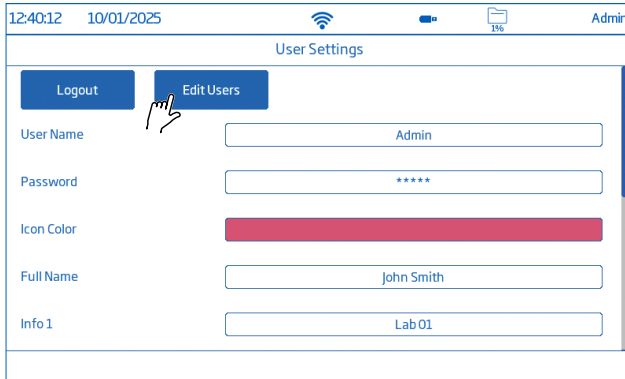

Log in & Create New Account

1. Tap  followed by .
2. Tap **Edit Users** to enter Account Management.

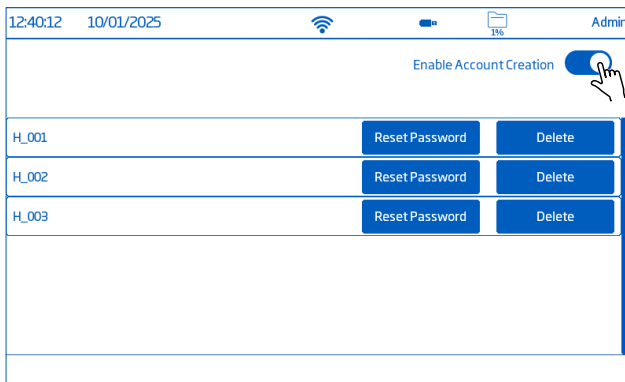

3. Tap  to enable Account Creation. Tap  to return.



4. Tap **Logout** to enter Users screen.
5. Tap the **plus** symbol avatar.
6. Input user name and tap .
7. Enter password and tap . Passwords must have at least 8 characters.
8. Reenter password to confirm.

Configure User Settings

Options: **Name, Password, Icon Color, Full Name, Information Fields, FTP-dedicated fields, Email Address**

- To edit option, tap field and use the on-screen keypad to input information.
- Use the FTP dedicated fields and email address for file transfer of logged data.

Log Out & Switch User

1. Tap  followed by **Logout**.
2. Tap on user's account avatar.
3. Input password.

Reset Password

1. Select user name from users list.
2. Tap **Reset Password**. The password is removed.

User will be prompted to enter a new password when selected from the log-in screen.

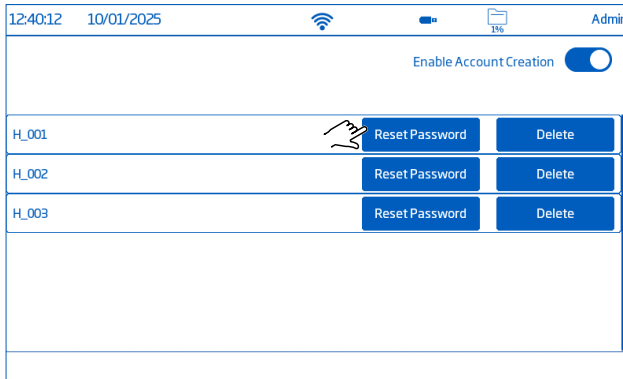

Delete Users

Select user name and tap **Delete**. The instrument prompts for confirmation.

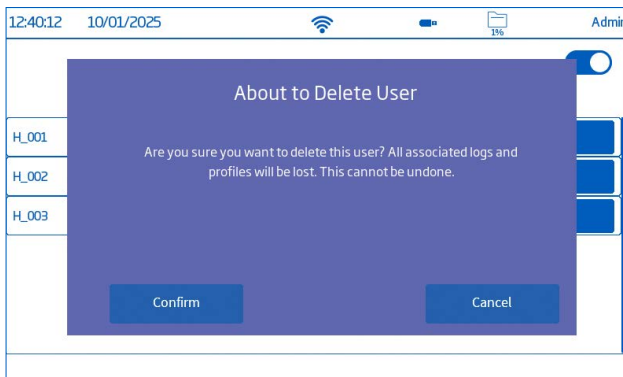

8.2. SYSTEM SETTINGS

System Settings is the second item under the System Menu.

Network, Certificates, Connect & Print, System, Info tabs permit users to navigate system settings and operations, configure network connection and architecture, install meter certificates, configure connectivity and printing services, change system settings, and view meter information.

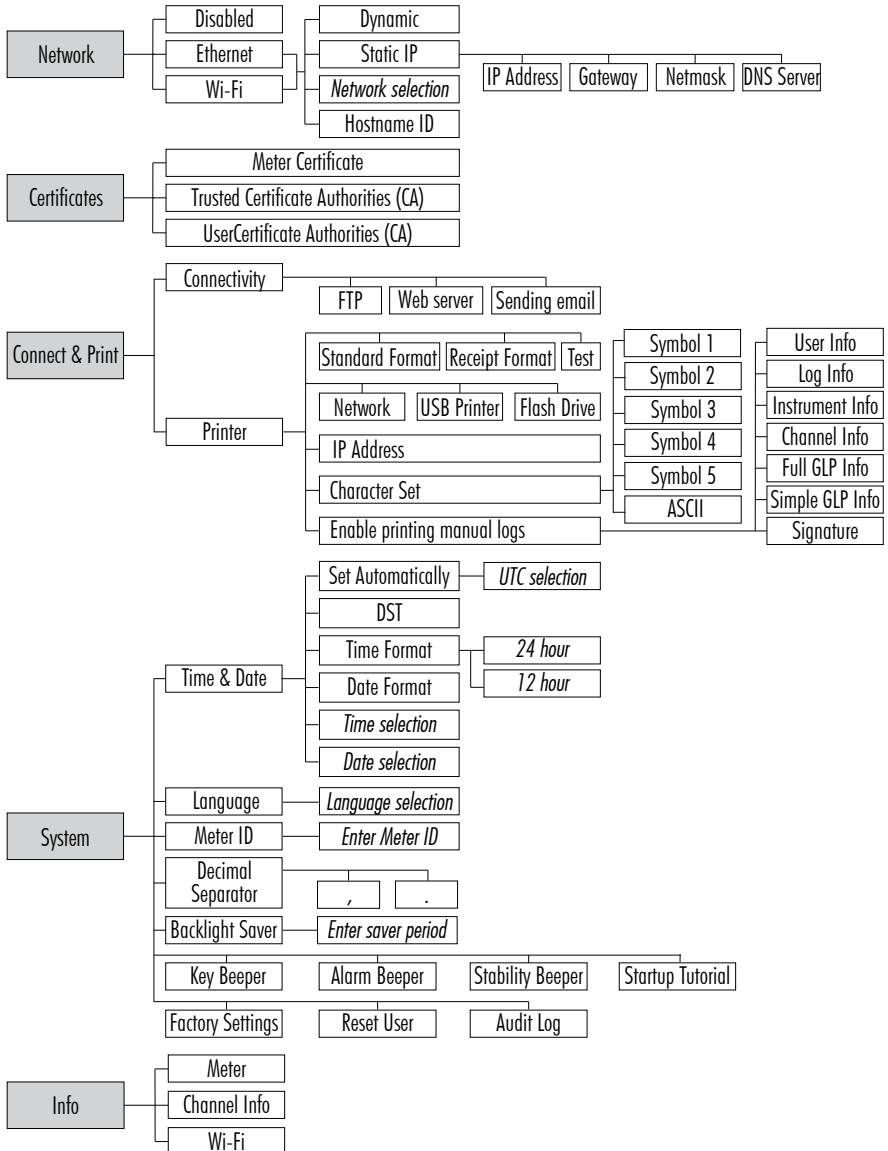

Network

Data sharing options: **Ethernet, Wi-Fi, Disabled**

With connection established, IP assignment can be set as:

- Dynamic » IP Address, Gateway, Netmask, DNS Server are being auto assigned
- Static » Network details are filled in manually
- Hostname ID » Filled in manually (range from 0 to 25)

The ID is used to access the meter's web server (<https://hi6000-xx.local>, where xx is the hostname ID)

Note: For customers with multiple devices, duplicate hostname IDs on a single network will cause connectivity issues for FTP/HTTPS.

In addition, some networks do not enable MDNS forwarding across network switches.

In these cases, the hostname may not be recognized so the IP address would need to be used instead.

To fill in network information, tap **IP Address** field then input address and tap .

Wi-Fi connectivity

1. Tap **Wi-Fi** then select the IP address type (Dynamic or Static).
2. Tap **Press to select network**.
3. Scan options and select preferred network. Enter password when prompted.
4. Tap  to confirm.

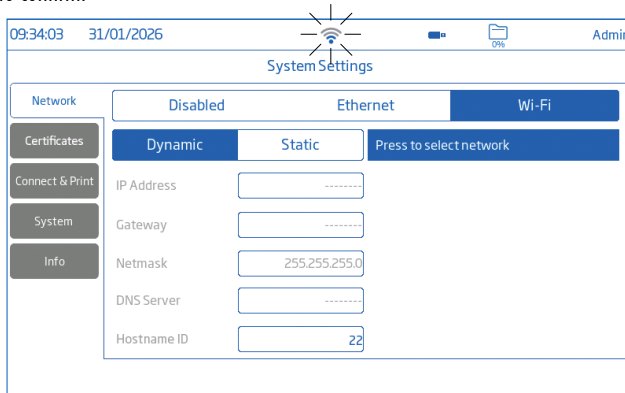

Note: With connection established, tap  or  to check IP address or verify connection status. When attempting to connect,  icon will blink until the connection is established.

Certificates

Digital certificates enable secure communication without security warnings across networks.

Options: **Meter Certificate**, **Trusted Certificate Authorities (CA)**, **User Certificate Authorities (CA)**

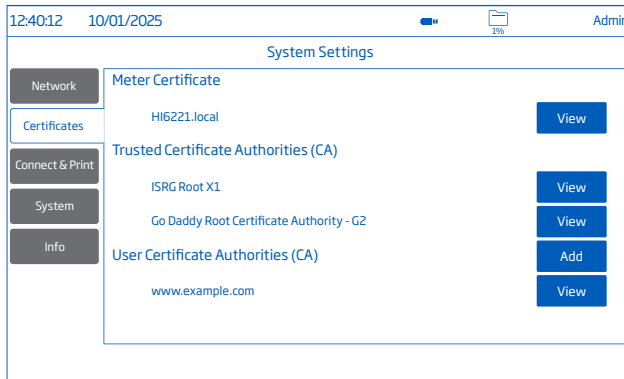

Meter Certificate

A meter certificate is an internal certificate that certifies HI6221 as a secure device to clients and browsers.

The **HI6221** has a certificate on the device that is signed by GlobalSign, a known certificate authority. GlobalSign CA certificate is used to sign **hi6000.local** certificate that identifies the meter to web browsers and FTP clients as a trusted site.

When connecting to the **HI6221** using a web browser or an FTPS session, the PC the user has connected to verifies that the Certificate Authority matches the one that they trust from GlobalSign.

In order to avoid security warnings, and establish secure PC to **HI6221** connections, users must install the meter certificate to their PC.

Note: Any application that connects to the meter (i.e. WinSCP, FileZilla, Chrome, Safari) will treat trusted certificates differently. See the documentation for your individual software for more information how certificates are handled.

To install the meter certificate on a PC:

- Obtain a certificate from the meter using the **View** and **Export** tabs.
- However, to install the certificate on a PC requires elevated privileges.

It is recommended to contact local IT department and have the certificate securely installed.

Trusted Certificate Authorities (CAs)

A **trusted certificate** is a **public (external) certificate** that certifies the server as secure to the HI6221. Certified Authorities are trusted organizations that verify digital identities and issue digital certificates, like SSL/TLS. At the protocol level, SSL/TLS certificates provide encryption for the communication channel and invite the use of certificates.

Through certificates, the communicating parties are authenticated, guaranteeing the server and/or the client are who they claim to be. If trust is established, the connection proceeds. Otherwise the connection fails.

Certificates contain key information e.g. who or what is being authenticated, a validity period, the issuer of the certificate i.e. self signed or through other authorities that can be trusted, the latter resulting in a “chain of trust”, leading to a root authority.

Internet connected devices maintain a trusted root-certificates store, ensuring that most connections run smoothly.

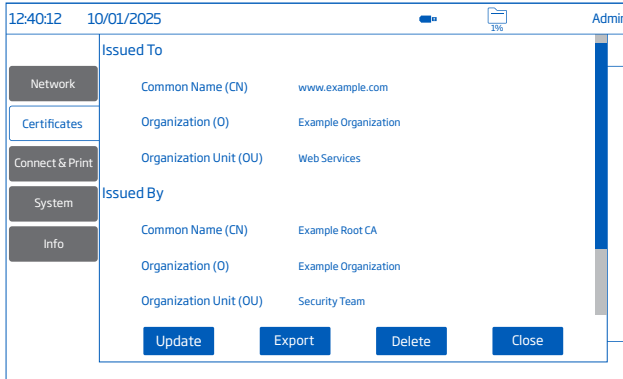

- Tap **View** to access certificate details.
- Tap **View** to access certificate **Export** / **Delete** options.

Add User Certificate Authorities (CA)

User has the option to add up to five custom user certificates.

- Tap **Add** and select the source USB to import a new User CA.

Note: Certificates must be in DER (binary) format (file extension must be .CER or .CRT).

- Tap **Export** to save the certificate to the USB drive inserted.
- Tap **Update** to update User CA.
- Tap **Delete** to delete User CA.

	Meter Certificate	Trusted CA	User CA
Scope	Certifies the device	Certifies website identity	Certifies user-FTP server
Install	Firmware update	Firmware update	User (up to a maximum of 5)
USB export	✓	✓	✓
Update/Delete	—	—	✓

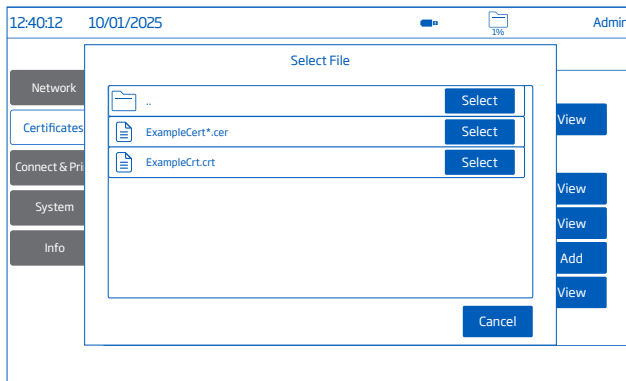
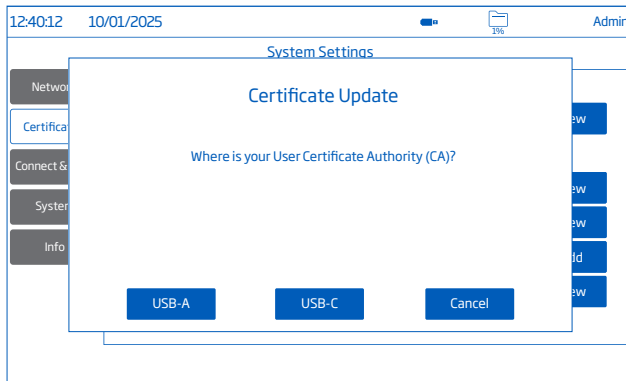

Connect & Print

Options: **Connectivity, Printer, Character Set**

Tap to enable (disable) following connectivity options for downloading log files:

- **FTP access:** user connects to the meter using a FTP client
- **Meter web server:** user connects to the meter using a web browser
- **Sending emails:** meter sends the files to the user email address (via Hanna Cloud)

A valid email address is required for file sharing.

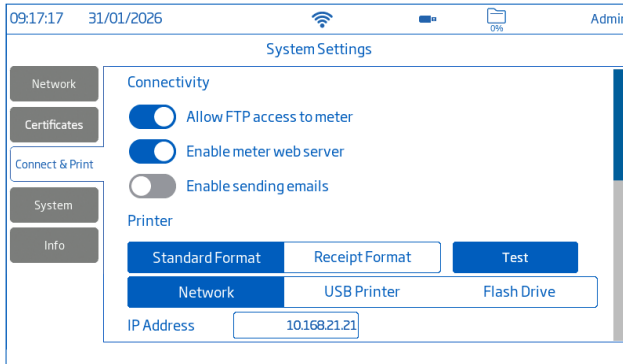

Printer

Options: **Standard Format, Receipt Format, Test**

- Select **Standard Format** to print the delimited text file.
 - Select **Receipt Format** to print data as individual points.
 - Select **Test** to verify connected printer is correctly configured and produces output correctly.
- Refer to printer manual for printer configuration options.

Note: Receipt format can be used on standard sized paper.

Options: **Network, USB Printer, Flash Drive**

- Select **Network** to connect a printer in the same network. Tap to enter IP address.
- Select **USB Printer** to connect a printer via USB-A port.
- Select **Flash Drive** to export log files directly to USB Flash Drive.

Character Set

Options: **Symbol 1** (character set CP-437), **Symbol 2** (character set CP-1252), **Symbol 3** (character set Roman-8), **Symbol 4** (character set CP-1257), **Symbol 5** (character set CP-1250), **ASCII**

- **Symbol 1** includes ASCII characters as well as some accented letters and Greek letters
- **Symbol 2** covers Western European languages
- **Symbol 3** covers Latin-based European languages
- **Symbol 4** covers Baltic languages
- **Symbol 5** covers Central and Eastern European languages
- **ASCII** (American Standard Code for Information Interchange) covers English language

Note: Selected character set must be supported by the printer.

- Tap Enable printing manual logs. When enabled, individual data points and enabled fields will be printed every time **M** is pressed.
- Tap to enable for printing: User, Log, Instrument, Channel, Full GLP, Simple GLP information, Signature.

Note: The connection to the printer must be made prior to enabling printing manual logs and fields to be printed.

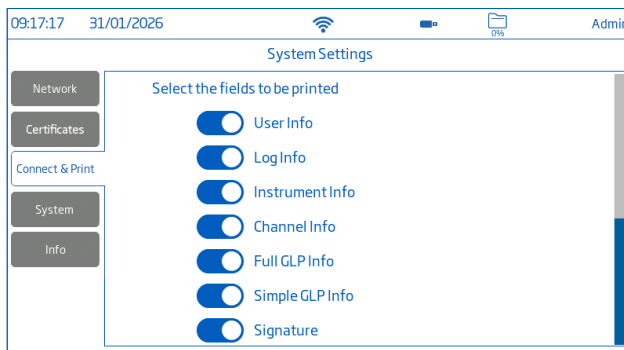
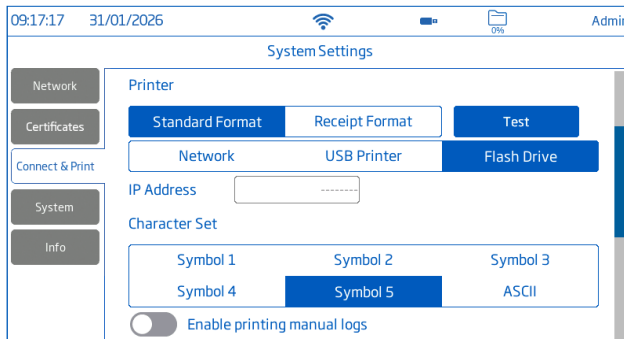

System

Options: **Time, Date, Language, Meter ID, Decimal Separator, Backlight Saver, Beepers, Startup Tutorial, Factory Settings, Reset User, Audit Log**

Note: Use the scroll bar to view or select from entire settings list.

Time & Date

Tap to enable or disable:

- **Set Automatically** (meter must be connected to the internet)
 - Direct selection from scrollable list of options
 - UTC options:
 - from UTC 00:00 to UTC+ 14:00
 - from UTC 00:00 to UTC - 12:00 (half hour increments)
- **DST** (Daylight Savings Time) seasonal time change is used in some locations that advances clocks (typically by one hour) during warmer months.

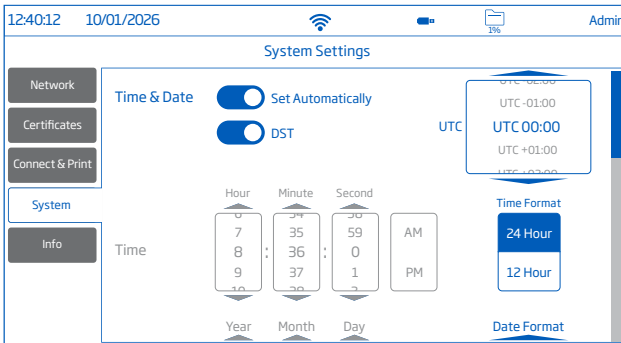

Time: Hour, Minute, Second, time of day (AM or PM), time format (24 or 12 Hour)

Note: Set Automatically must be disabled

Date: Year, Month, Day, choice of display formats (DD-Mon-YYYY; YYYY-Mon-DD; DD/MM/YYYY; MM/DD/YYYY; YYYY/MM/DD; YYYY-MM-DD; Mon DD, YYYY)

Note: Set Automatically must be disabled

Language: select from list of supported options to change meter's interface language

Meter ID (Admin only)

- Name the meter with a discrete name, location, or number. Tap  to save.

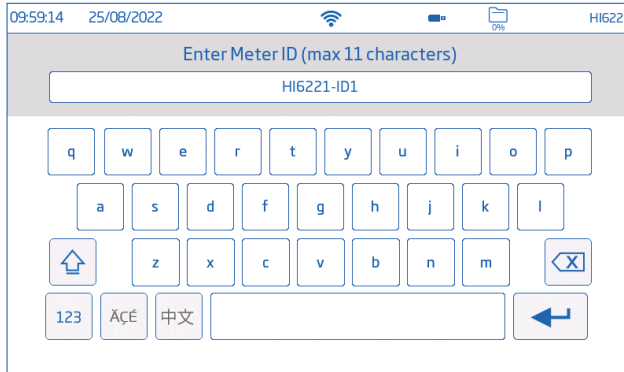

09:59:14 25/08/2022 HI6221

Enter Meter ID (max 11 characters)

HI6221-ID1

q w e r t y u i o p
a s d f g h j k l
⬆ z x c v b n m ⬇
123 Æ Ç É 中文 ⬅

Tap  or corresponding tab to configure following settings:

- **Decimal Separator:** Comma or Period
- **Backlight Saver:** Enabled or Disabled, 1 to 60 minutes
If the backlight turns off after the set period of time, tap to turn it back on.
- **Beeper:** Key, Alarm, Stability
When enabled, an audible signal alerts users in the event of a wrong key press, an alarm condition, or the stability threshold being exceeded.
- **Startup Tutorial:** Enabled or Disabled
If disabled, the meter does not launch into Tutorial at power on.

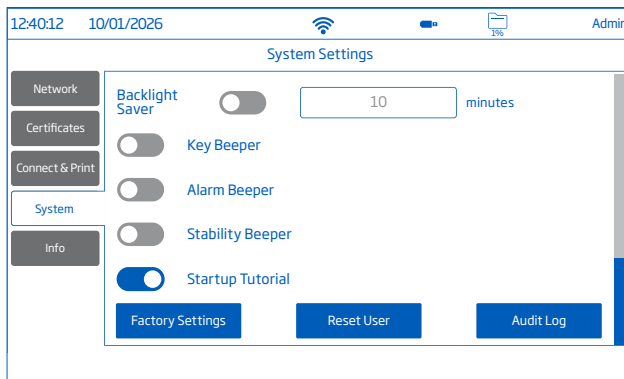

12:40:12 10/01/2026 Admin

System Settings

Network

Certificates

Connect & Print

System

Info

Backlight Saver 10 minutes

Key Beeper

Alarm Beeper

Stability Beeper

Startup Tutorial

Factory Settings Reset User Audit Log

Factory Settings (Admin only)

Option restores following system settings: resolution for measured data, temperature unit, view mode, and alarm to original factory values.

Restoring factory settings deletes all user information, calibrations, logs, or configured measurement profiles. When option invoked, the instrument asks for confirmation.

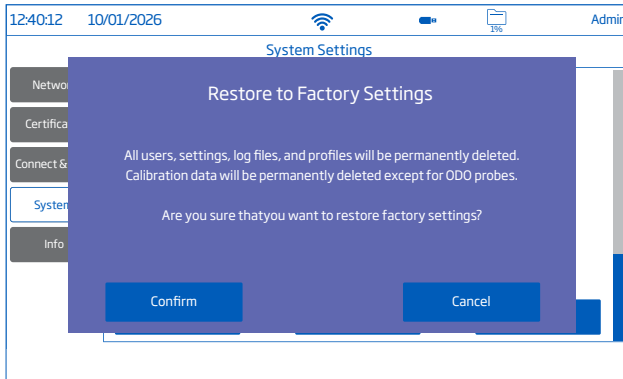

Reset User

Option restores default settings for this user.

All data (including profiles and log files) specific to this user will be permanently deleted, except for the username, password, and calibrations.

When option invoked, the instrument asks for confirmation.

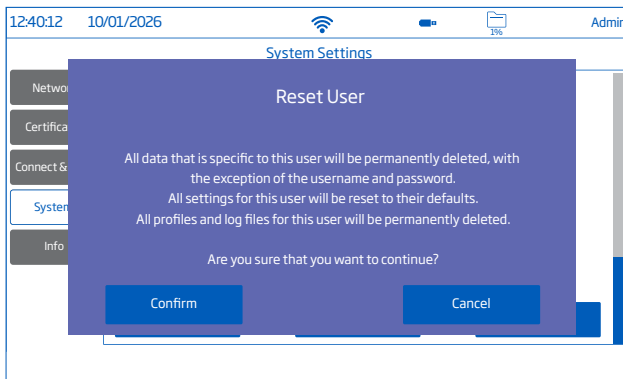

Audit Log (Admin only)

The audit log is a security-focused, chronological set of records that provide evidence of the sequence of activities that have affected at any time the device. These records track users actions, system events, security changes, making them vital for detecting anomalies and ensuring compliance.

- Tap **Audit Log** to list available log entries. Each row represents an audit log entry.
- Tap **Print** to print the log.
- Tap **Export** to save the .csv log file to a USB flash drive.

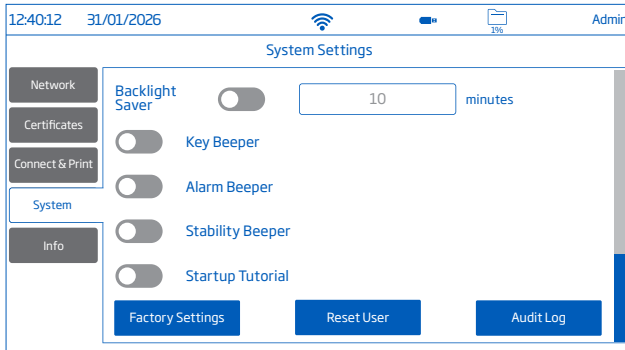

12:40:12 31/01/2026 Admin

Audit Log **Print** **Export**

Index	Date	Time	User	Action
0	10.20.2025	12:45:42	SYSTEM	Create Audit Log
1	10.20.2025	12:45:45	Admin	Create 20251020_125909-pH_auto2.csv
2	10.20.2025	12:45:46	Admin	Print 20251020_125909-pH_auto2.csv

Info

Displays information on meter, channel serial number, and Wi-Fi firmware version.

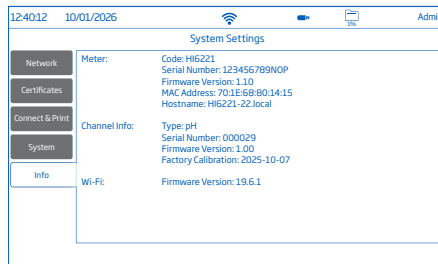

8.3. MEASUREMENT SETTINGS

Measurement Settings is the third item under the System Menu.

Tap  icon to access Measurement Settings screen.

Measurement Settings has the following tabs to help the user navigate through all the measurement operations:

Calibration, Reading, Temperature, View, Alarms, Logging, Profiles.

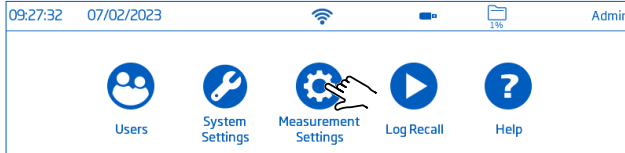

Calibration

	pH	mV	Rel.mV
Last Calibration	Calibrate Clear	✓	Calibrate Clear
Buffer Entry Type	Automatic Semiautomatic Manual	✓	✓
Buffer Auto Confirmation	Enabled Disabled	—	—
First Calibration Point	Point Offset	✓	✓
Calibration Reminder	Disabled Daily Periodic	✓	Disabled Daily Periodic
Buffer Group	User defined	✓	✓

Reading

	pH	mV	Rel.mV
Resolution	0.1 0.01 0.001	1 0.1	1 0.1
Stability Criteria	Accurate, Medium, Fast		
Reading Mode	Direct, Direct/Autohold		

Temperature

	pH	mV	Rel.mV
Temperature Source	Automatic, Manual		
Temperature Unit	°C, °F, K		
Manual	-20.0 to 120.0 °C -4.0 to 248.0 °F 253.2 to 393.2 K		
Isopotential Point	user defined (-2.000 to 20.000)	✓	✓
User Temperature Calibration	Calibrate, Clear		

View

	pH	mV	Rel.mV
View Type	Basic Simple GLP Full GLP Graph Table	Basic Graph Table	Basic Simple GLP Graph Table

Alarms

	pH	mV	Rel.mV
High / Low pH	-2.000 to 20.000	✓	✓
High / Low mV	✓	-2000.0 to 2000.0	
High / Low Temperature	-20.0 to 120.0 °C -4.0 to 248.0 °F 253.2 to 393.2 K		

Logging

	pH	mV	Rel.mV
Logging Type	Automatic Manual Autohold (Direct/Autohold Reading mode only)		
Sampling Period (Automatic type only)	1, 2, 5, 10, 30 sec. 1, 2, 5, 10, 15, 30, 60, 120, 150, 180 min.		
File Name (Manual & Autohold only)	Create Unnamed Log		
Log Note	User defined		
Log Info 1 through to 4	User defined		
Sample ID Prefix (Manual or Autohold only)	0 to 999		

Profiles

	pH	mV	Rel.mV
Profile Feature	Enable Disable		
Current Profile	Save As Save Delete		
Load Profile	Previously defined profiles		

8.4. LOG RECALL

Log Recall is the fourth item under the System's Menu and allows data selection, viewing, sharing, and deletion.

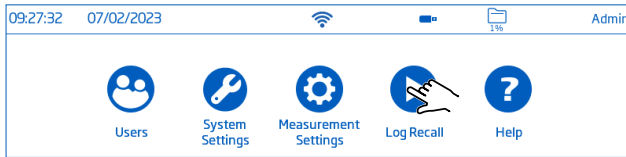



- Logged data is retrieved by the user that has logged the measurement.
- Data is stored in parameter-specific .CSV files: pH, mV, and Rel.mV.
- Storage location is independent and organized in lots.
- A lot (file) can store 1 to 50 000 data points.
- One user can store up to 255 MB of data points.

View

Data can be viewed, plotted (graph), or tabulated (complete with date, time, notes).



From the System Menu screen:

1. Tap  to display the Log Recall screen.
The log files can be sorted by name or start time.
Tap on the corresponding table header, then tap the  icon to reverse the order.
2. Tap to select .CSV file.
3. Tap **View** to open the file .



The screenshot shows the 'Log Recall' screen with a table of CSV files. The table has columns for Name, Parameter, Start/Stop, and #Samples. The files listed are:

Name	Parameter	Start/Stop	#Samples
20220326_065354-pH_auto.csv	pH	08:53:54 26/03/2022 08:53:57 26/03/2022	4
20220326_085358-pH_auto.csv	pH	08:53:58 26/03/2022 08:54:06 26/03/2022	9
20220326_114046-pH_auto.csv	pH	14:39:57 26/03/2022 14:40:15 26/03/2022	19
20220326_114309-pH_man-Lab12_002.csv	pH	14:40:47 26/03/2022 14:41:04 26/03/2022	18
20220326_114523-pH_man-Lab12_003.csv	pH	14:44:35 26/03/2022 14:44:36 26/03/2022	27
20220326_115959-mV_man-Lab12_004.csv	mV	14:46:01 26/03/2022 14:46:02 26/03/2022	19

Log Recall



- Tap  or  icon to have logged data displayed in tabulated form or plotted.
- Tap  to view additional information about the log file including user information, log information, meter information, and GLP data.

10:06:02 03/03/2022 13% HI6221

20220326_114523-pH_man-Lab12_003.csv   

Index	Date	Time	pH	pH-mV	T[°C] ATC	Notes
1	26/03/2022	14:45:23	9.0	-116.7	25.0	"H"
2	26/03/2022	14:45:24	9.0	-116.7	25.0	"H"
3	26/03/2022	14:45:25	9.0	-116.7	25.0	"H"
4	26/03/2022	14:45:26	9.0	-116.7	25.0	"H"
5	26/03/2022	14:45:28	9.0	-117.1	25.0	OK
6	26/03/2022	14:45:29	8.8	-108.0	25.0	OK
7	26/03/2022	14:45:30	8.8	-108.2	25.0	OK
8	26/03/2022	14:45:31	8.8	-108.2	25.0	OK
9	26/03/2022	14:45:32	8.7	-99.4	25.0	OK
10	26/03/2022	14:45:33	8.7	-99.5	25.0	OK

10:07:53 03/03/2022 13% HI6221

20220326_113957-pH_auto.csv   

USER INFO
 User Name: HI6221
 Full Name: John Smith
 Info 1: Hanna Instruments
 Info 2: Addr
 Info 3:
 Info 4:

LOG INFO
 Log Note:
 Log Info 1:
 Log Info 2:

With USB flash drive connected, tap **Save Bitmap** to save plotted data as image.

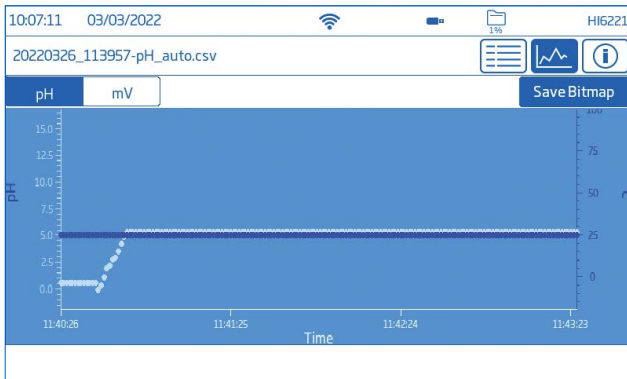

Delete

Deleting logs frees up log space for additional log files.

1. Select the log files to be deleted.
Multiple files can be selected individually or all files can be selected using **Select All**.
2. Tap **Delete**.
3. The instrument prompts for confirmation.

Deleted files can not be recovered. If all of the files have been deleted the log recall screen will be blank.

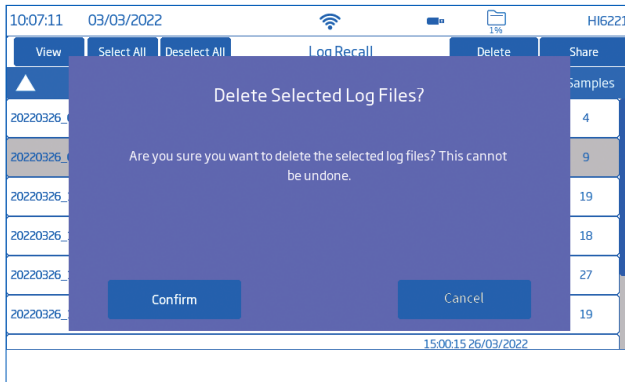

Share

Options: **USB, FTP, Email, Print**

USB

1. Plug the USB-A or USB-C flash drive into the USB port located on the back.
2. Select the log files to be shared.
Multiple files can be selected individually or all files can be selected using **Select All**.
3. Tap **Share**.
4. Tap to select USB-A or USB-C. ⌚ is displayed during data transfer.
Transfer completion is confirmed and the instrument returns to Log Recall screen.

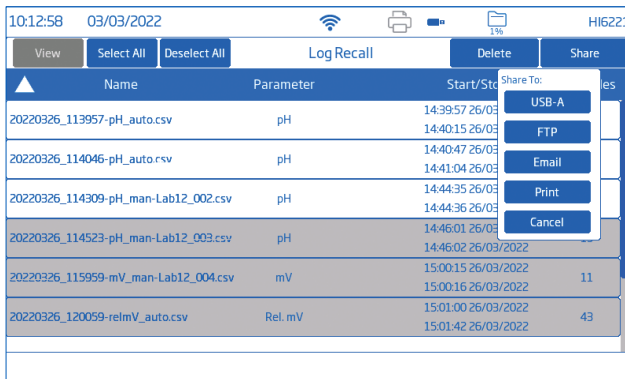

FTPS

HI6221 Meter as FTPS Client

When HI6221 connects as a client to an FTP server, to establish secure connection, it is recommended to contact technical IT department and obtain server's SSL/TLS certificate.

Setting up an FTP server requires elevated rights for installation and configuration as well as firewall permissions.

1. Export the digital certificate to a USB device.
2. Insert the USB into the meter.
3. To install the FTP server's Certificate Authority (CA) onto the meter:

Note: the HI6221 requires installing the CA that signed the certificate of the FTP server, not the certificate itself. This can be extracted from the FTP Server certificate in the DER (binary) format that is required by the HI6221.

- Navigate to **System Settings** » **Certificates** section.
- Tap **Add**.
- Select the Certificate Authority from the plugged in USB and upload to the HI6221 certificates store.
- Once loaded, the certificate is listed under User Certificate Authorities (CA).

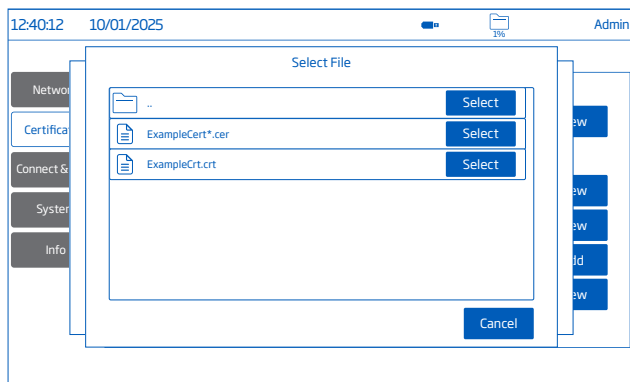
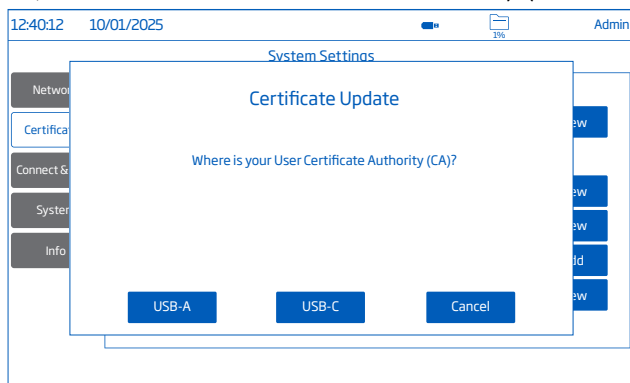

4. Connect to FTP.

Go to **System Settings** › **Users** and configure the following:

- FTP IP address
- FTP user name
- FTP password

The meter will now use the installed CA certificate to verify the server's identity before transferring files securely.

To share files:

1. Navigate to **System Settings** › **Connect & Print** and tap "Allow FTP access to meter".
2. Navigate to **Log Recall** or **Reports**.
3. Select the log files to be shared.

Multiple files can be selected individually or all files can be selected using **Select All**.

4. Tap **Share** then tap to select FTP.

The files are being transferred to the FTP Directory (defined in User Settings) of the server.

 is displayed during data transfer.

Transfer completion is confirmed and the instrument returns to Log Recall screen.

Email

Meter has to be connected to the internet and sending emails is enabled.

Enter email address in the User menu () to share log files via email.

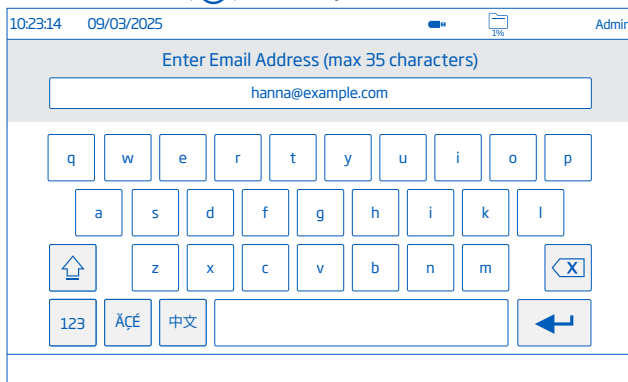

10:23:14 09/03/2025 33% Admin

Enter Email Address (max 35 characters)

hanna@example.com

q w e r t y u i o p
 a s d f g h i k l
 ↵ z x c v b n m ⌫
 123 Æ Ç É 中文 ⬅

1. Select the log files to be shared.

Multiple files can be selected individually or all files can be selected using **Select All**.

2. Tap **Share** then select **Email**.

3. Tap to select email.

The files are being emailed.  is displayed during data transfer.

Transfer completion is confirmed and the instrument returns to Log Recall screen.

Print

1. Connect either a printer (Network or USB) or plug-in a USB Flash Drive.
2. Select the log files to be printed.
Multiple files can be selected individually or all files can be selected using **Select All**.
3. Tap **Share**.
4. Tap **Print** and follow on-screen instructions

HI6221 Meter as Server

HTTPS Connections

Any browser can be used to access the **HI6221** device and download log files.

To view or download the files, users might need to adjust browser or network settings for permissions.

Enable meter web server option has to be enabled.

The meter and the browser have to be connected to the same network.

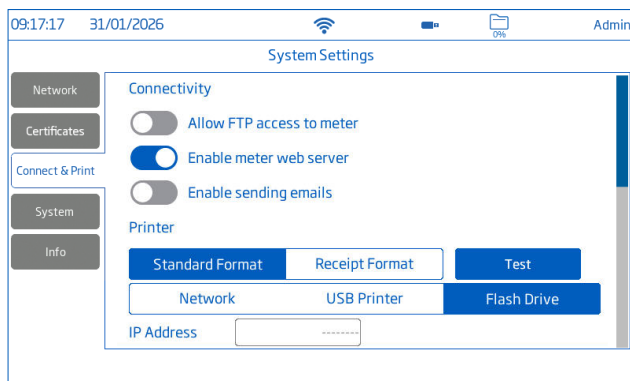

Option 1 > use meter IP address

1. Tap for IP address and type address in the browser.



2. Enter the username and password of current user to gain access to logs.
3. Click on file to download to the PC.

Option 2 > use meter hostname

1. In the browser enter **hi6000-xx.local** ("xx" = meter hostname ID)
2. If the GlobalSign root CA off the meter has not been installed on the system, the connection is marked as "Not secure".
3. If MDNS forwarding is not enabled on the users network, depending on the configuration, the hostname may not be recognized and the IP address must be used.

Once the GlobalSign root CA certificate has been installed on the system, the connection is marked as secure.

FTPS Connections

Any FTP client can be used to access the device and download log files.

FTP configuration using WinSCP as file manager

- Log in to the meter.
Note that meter login credentials are to be used for FTP as well.
- The meter has to be connected to the internet and **Allow FTP access to meter** enabled.
- Set the hostname ID.
- Open preferred file manager and configure connection session.

Note: Port number “21” needs to be used and “TLS/SSL Explicit encryption” is required.

Details given here use WinSCP as an example.

File protocol	FTP
Encryption	TLS/SSL Explicit encryption
Hostname	hi6000-22.local (“22” = meter hostname ID) or IP Address

Username & Password Meter login credentials

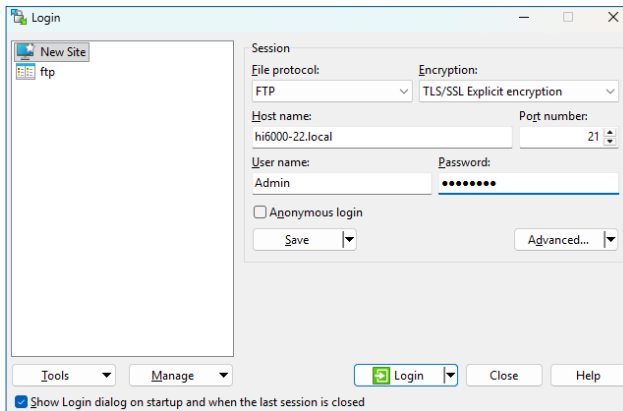

- Press “Login” to access the report or log files off the meter.
The meter proves its identity by presenting its TLS certificate.
The user is next prompted to “Continue connecting and store the certificate?” Select “Yes”.

Note: When connecting a second time with the same credentials the user is no longer prompted to trust the certificate.

PC Connection

The logged data can be transferred from the meter to a PC.

1. Use the USB-C cable to connect the meter to the PC. The meter appears as a flash drive on the computer.
2. Select the log files to be shared.

Multiple files can be selected individually or all files can be selected using **Select All**.

3. Tap **Share**.
4. Save files to the PC.

All files will be listed as .CSV and may be opened with any text editor or spreadsheet application.

8.5. HELP

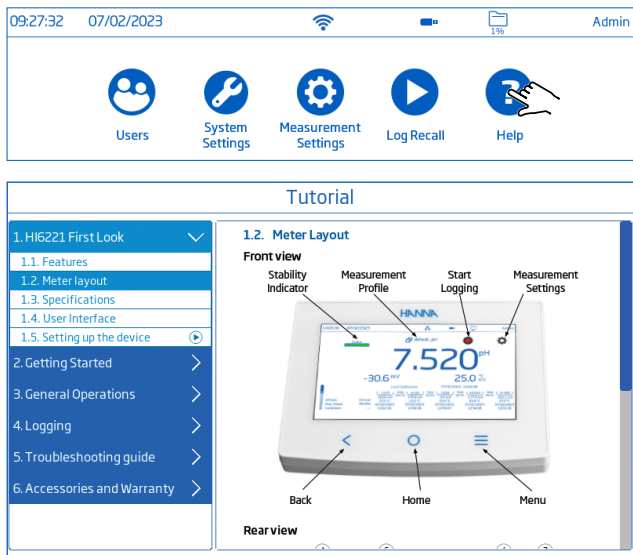

Help is the fifth item under the System Menu.

- Tap  to access support and navigate through an overview of system's main functionalities.



- Tap  to play video-supported segments.
- Drag the slider along the progress bar to fast forward or rewind the video.

9. MEASUREMENT & ELECTRODE SETUP MENU

- Tap  icon to access Measurement Settings screen. Measurement Settings has the following tabs to help the user navigate through all the measurement operations: **Calibration, Reading, Temperature, View, Alarms, Logging, Profiles.**
- Alternatively, tap  key (**Menu**), then  icon.

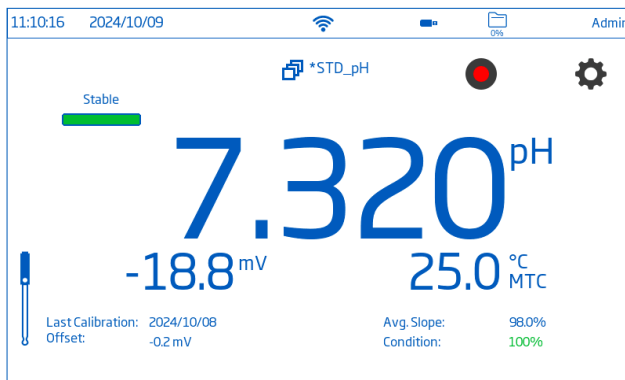

9.1. CALIBRATION

Options: **Last Calibration, Buffer Entry Type, Buffer Auto Confirmation, First Calibration Point, Calibration Reminder, Buffer Group**

Last Calibration: calibrate or clear a previous calibration

“Calibrate” starts a new user calibration and “Clear” deletes an electrode calibration.

Buffer Entry Type

- **Automatic:** the instrument automatically selects the closest buffer value to that of the pH sample being measured from all active buffers in the buffer group
- **Semiautomatic:** the instrument automatically selects the closest buffers to that of the pH sample being measured from all available standard and custom buffers
The user has the option to manually select between buffers that are close in value.
- **Manual:** user manually selects the buffer value from all available standard and custom buffers

Buffer Auto Confirmation

With option selected, recognized buffer value is automatically accepted when the reading is stable.

First Calibration Point

- **Point:** a new buffer value can be added to an existing calibration.
This prompts an automatic reevaluation of the electrode slope.
- **Offset:** the new buffer calibration point can create a constant offset to all existing pH calibration data performed with a minimum of two pH buffers.

Calibration Reminder

- **Daily:** set the time of day the calibration reminder needs to be displayed.
- **Periodic:** schedule time in days, hours and/or minutes after the last calibration for the calibration reminder to be displayed.

“Calibrate probe” message is displayed after the calibration reminder period has elapsed.

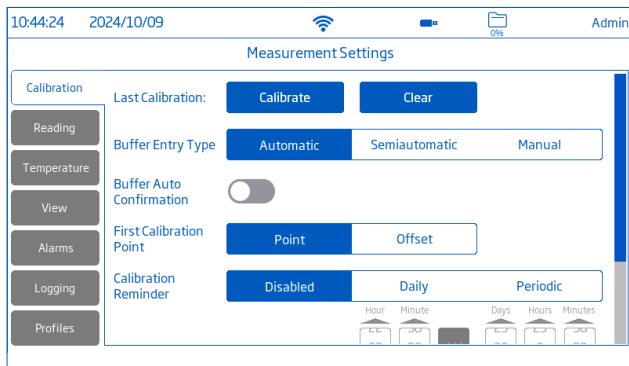

Buffer Group

The buffer group is used during calibration when automatic buffer entry type is selected.

The instrument automatically selects closest buffer to the pH value being measured from the buffer group.

To move from **Standard/Custom Buffers** to the **Buffers in Use** column, select buffer and forward arrow.

To edit and add a custom buffer:

1. From measurement screen tap .
2. Tap **Reading** tab and set pH Parameter.
3. Tap **Calibration** tab.
4. Tap **Edit** next to Buffer Group.
5. Select from available input field in the Available Custom Buffers list.
6. Tap **Edit** to enter buffer value at the calibration temperature value and **Enter** to confirm.
7. Repeat with up to 5 custom values.

Once the maximum number has been reached, to add another custom value, delete a previously set value.

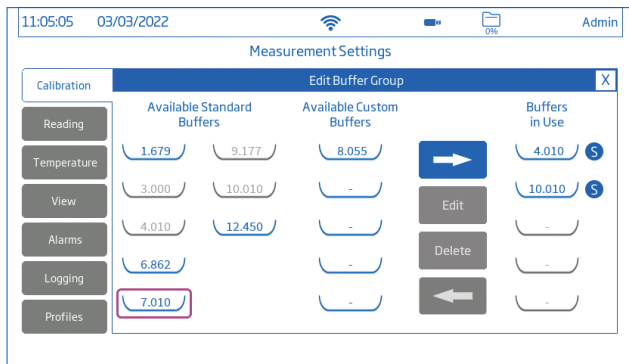

9.2. READING

Options: **Parameter**, **Resolution**, **Stability Criteria**, **Reading Mode**

The screenshot shows the 'Measurement Settings' interface. On the left is a vertical sidebar with buttons for 'Calibration', 'Reading', 'Temperature', 'View', 'Alarms', 'Logging', and 'Profiles'. The main area is titled 'Measurement Settings' and contains four rows of settings:

- Parameter:** Three buttons labeled 'pH', 'mV', and 'Rel. mV'. The 'pH' button is highlighted in blue.
- Resolution:** Three buttons labeled '0.1', '0.01', and '0.001'. The '0.001' button is highlighted in blue.
- Stability Criteria:** Three buttons labeled 'Accurate', 'Medium', and 'Fast'. The 'Medium' button is highlighted in blue.
- Reading Mode:** Two buttons labeled 'Direct' and 'Direct/Autohold'. The 'Direct' button is highlighted in blue.

Parameter

Options: **pH**, **mV**, **Rel. mV**

Tap to select measurement configuration: pH, mV (ORP), Rel. mV (ORP with calibration).

Resolution

Options: **0.1**, **0.01**, **0.001**

Tap to select the pH measurement resolution.

Stability Criteria

Options: **Accurate**, **Medium**, **Fast**



- **Accurate:** for applications where high accuracy is required
Measurement is recognized as stable using more critical criteria evaluating measurement fluctuations.
- **Medium:** for applications where average accuracy is accepted
Measurement is recognized as stable using less critical criteria evaluating measurement fluctuations.
The measurement may still change after registering stable.
- **Fast:** for applications where speed of delivery has priority

While the measurement is changing, **Unstable** indicator is displayed.

When the criteria is reached, **Stable** indicator is displayed.

Reading Mode

Options: **Direct**, **Direct/Autohold**

- **Direct**: as measurement changes measurement stability is continuously evaluated. “Unstable” (blinking) or “Stable” is displayed above the stability indicator.
- **Direct/Autohold**: measurements are initiated using the  icon.
 - When the measurement is stable, the icon is frozen on the display.
 -  is displayed blinking until the measurement is stable.
 - The  is used to release the autohold reading.

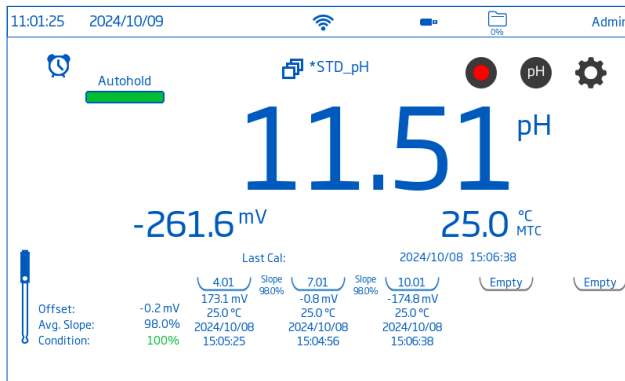

9.3. TEMPERATURE

Options: **Temperature Source**, **Temperature Unit**, **Manual**, **Isopotential Point** (pH parameter only), **User Temperature Calibration**

The screenshot shows the 'Measurement Settings' screen. At the top, there is a status bar with the time 15:39:23, date 26/03/2022, and an 'Admin' user. Below the title 'Measurement Settings', there is a sidebar menu with options: Calibration, Reading, Temperature, View, Alarms, Logging, and Profiles. The main content area has the following settings:

- Temperature Source:** A toggle switch set to 'Automatic' (highlighted in blue) with 'Manual' as an alternative option.
- Temperature Unit:** A selection menu with '°C' (highlighted in blue), '°F', and 'K' options.
- Manual:** An input field containing '25,0' with a '°C' unit indicator to its right.
- Isopotential Point:** An input field containing '7.000' with a 'pH' unit indicator to its right.
- User Temperature Calibration:** Two buttons, 'Calibrate' and 'Clear', are present. To the right, it says 'Last Calibration 26/03/2022'.

Temperature Source: Automatic, Manual

User can select between physical temperature input source (Automatic) or entering sample temperature value manually (Manual).

- **Automatic** with temperature probe
ATC is displayed next to the temperature measurement on the measurement screen.
- **Manual** without temperature probe
MTC is displayed next to the temperature measurement on the measurement screen.
Sample's temperature needs to be entered.

Temperature Unit: Celsius, Fahrenheit, Kelvin degrees

- Tap to select unit.

Manual

To manually input value:

1. Select temperature unit.
2. Tap the Manual Temperature input field.
3. Enter temperature value.
4. Tap  to confirm.

Isopotential Point: —2.000 pH to 20.000 pH

Isopotential point is the point at which temperature has no effect on pH readings.

Unless noted with electrode, use 7.000 pH.

To change the isopotential point:

1. Tap the isopotential point input field.
2. Enter isopotential point.
3. Tap  to confirm.

User Temperature Calibration

Options: **Calibrate** or **Clear**

- **Calibrate**: starts a new user calibration.
- **Clear**: deletes the temperature calibration for the selected hardware module.

To perform a new calibration:

1. Tap **Calibrate**.
2. Place the temperature probe and a reference thermometer with 0.1 resolution into a stirred container of water.
Allow for the reading to stabilize.
3. If the displayed value is different than the reference thermometer reading, tap **Calibrated Temperature** and use the on-screen keypad to edit.
4. Tap **Save** to confirm and save data.

15:37:16 26/03/2022 Wi-Fi Battery 0% HIG221

Calibrate temperature

Measured Temperature: °C

Calibrated Temperature: °C

Check if the displayed value is different than the reference thermometer reading.
If yes, touch the preset temperature value to change it, else press 'Save' to save the calibration data.

9.4. VIEW

Options: Basic, Simple GLP, Full GLP (pH), Graph, Table

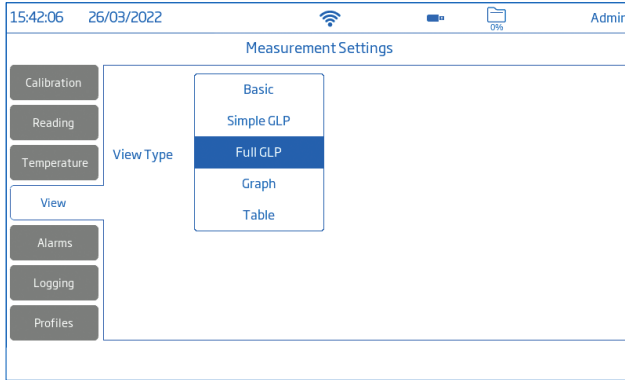

Basic

Screen displays the measured value, measurement unit, stability, temperature compensation status and source.

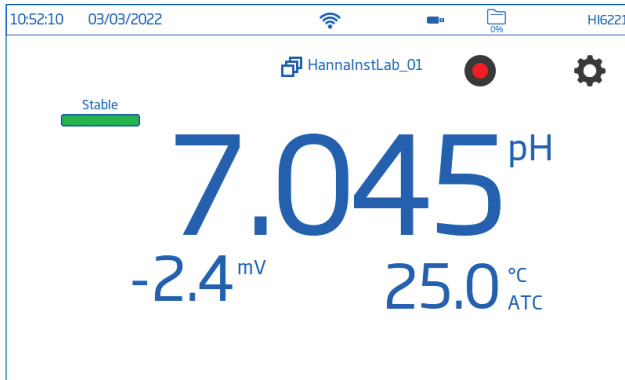

Simple GLP

Screen displays the last calibration date and time, and basic calibration information. The displayed information will vary based on the parameter selected.

Note: If the calibration is not available, "Not Calibrated" is displayed. Simple GLP is not available for all reading modes.

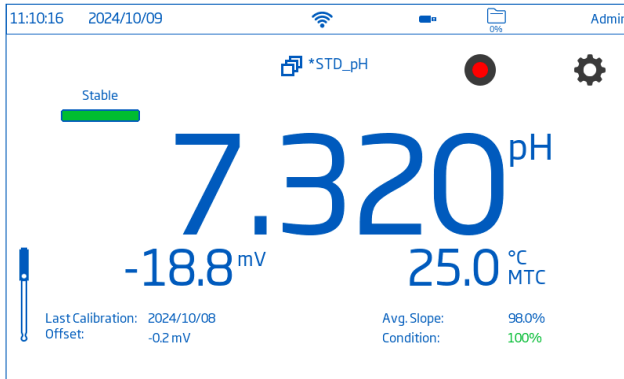

Full GLP

Screen displays the last calibration date and time, and full calibration information. The displayed information will vary based on the parameter selected.

Note: If the calibration is not available, "Not Calibrated" is displayed. Full GLP is not available for all modes.

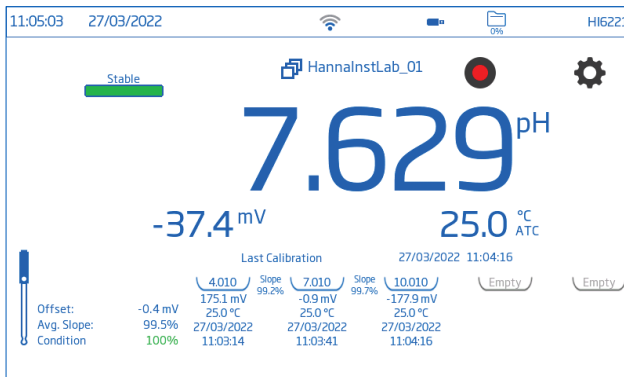

Graph

Measured values are plotted as a graph that can be zoomed and panned.

To zoom in on the graph, select the time or parameter axis and pinch on the display. Once zoomed, the graph position can be adjusted by dragging on the display.



Table

When Table is selected, the measured values are displayed tabulated with date, time, notes made during logging. The newest data is displayed on the top of the table.

The screenshot shows a data table interface. At the top, it displays the time 13:07:57 and date 07/02/2023. The current pH is 7.520 and the temperature is 25.0°C MTC. The table below lists 13 rows of data with columns for pH, mV, T(°C), Time, Date, and Notes. The data shows a stable pH of approximately 7.52 and a constant temperature of 25.0°C.

pH	mV	T(°C)	Time	Date	Notes
7.521	-30.6	25.0	13:07:56	07/02/2023	
7.521	-30.6	25.0	13:07:55	07/02/2023	
7.521	-30.7	25.0	13:07:54	07/02/2023	
7.521	-30.7	25.0	13:07:53	07/02/2023	
7.521	-30.7	25.0	13:07:52	07/02/2023	
7.521	-30.6	25.0	13:07:51	07/02/2023	
7.521	-30.7	25.0	13:07:50	07/02/2023	
7.521	-30.7	25.0	13:07:49	07/02/2023	
7.521	-30.6	25.0	13:07:48	07/02/2023	
7.521	-30.7	25.0	13:07:47	07/02/2023	
7.520	-30.6	25.0	13:07:46	07/02/2023	

9.5. ALARMS

Options: **High / Low** threshold limits (parameter specific)

Users can set the threshold limits for the measured parameters.

When enabled, the measurement exceeds the high-threshold value or drops below the low-threshold value, the alarm is triggered, and an alarm message is displayed.

If the alarm beeper is enabled, an audible beep will be heard.

Select the **Alarms** tab to configure module-specific alarm options.

To set an alarm limit:

1. Tap  to enable low or high threshold option.
2. Use the on-screen keypad to enter the value.
Alarm values cannot exceed the corresponding high or low alarm.
3. Tap **Save** to confirm.
4. Alternatively, tap **Cancel** to exit and return to measurement settings.

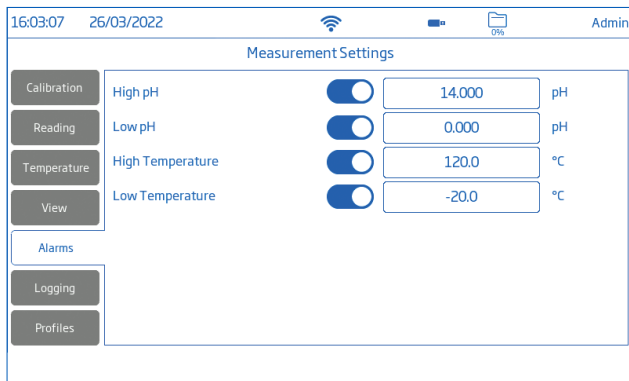

9.6. LOGGING

A complete set of GLP information including date, time, temperature reading, and calibration information is stored with each log.

User and log information (e.g. company address or sample details) are included on the .CSV file.

Company information may be entered on the Logging tab in the measurement settings.

User information is entered in the User menu in the system menu.

Logging Type & Log Naming Convention

Options: **Logging Type**, **Sampling Period**, **File Name**, **Log Note**, **Log Info**, **Sample ID**

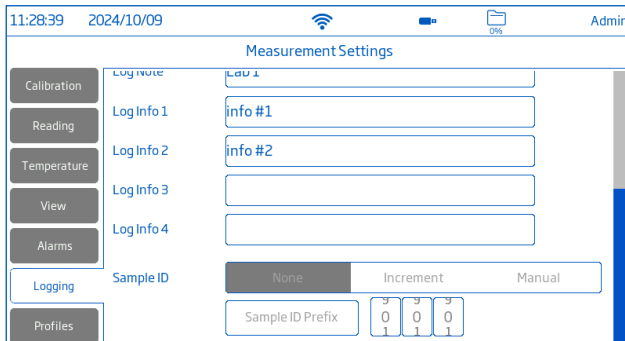
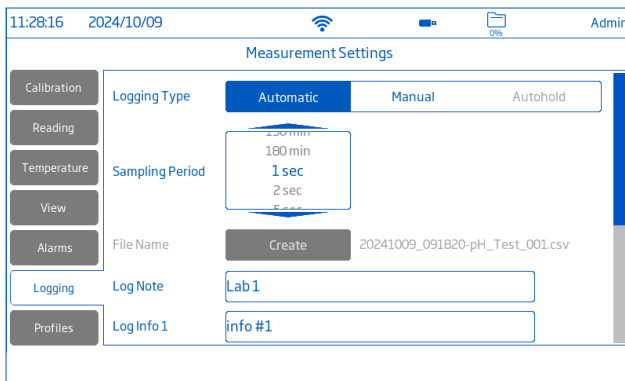



Logging Type

Options: **Automatic, Manual, Autohold**

Automatic

Readings are logged automatically at predefined time intervals, from 1 second to 180 minutes.

- Tap  to start.
Records are continuously added to the log until the session stops.
- Tap  to stop.
- For each automatic logging session, a new log file is created.
A file name is automatically generated, with the year, month, date and log starting time.
 - pH log files
20250329_085101-pH_auto.CSV
 - mV log files
20250429_084105-mV_auto.CSV
 - Rel.mV log files
20250309_095704-relmV_auto.CSV

Manual

- Readings are logged every time  is tapped.
- All manual readings are stored in a single log (e.g. records made on different days share the same log).
- A file name is automatically generated with the year, month, date and log starting time.
Files are identified by parameter.
- Tap **Create** to name a manual log file with a custom suffix, e.g. 20250329_085104-pH_HannaSamples.

Autohold

- Available with Direct/Autohold reading mode only.
- Readings are logged each time  is tapped and configured stability criteria is reached.
- A file name is automatically generated, with the year, month, date and log starting time, e.g. 20250329_085101-pH_001.
- Tap **Create** to name a manual log file with a custom suffix, e.g. 20250404_085501-pH_HannaSamples.

Notes:

- *Manual and Autohold records are stored in the same log file, e.g. data logged on different days is stored in the same file. Automatic records are stored separately.*
- *Data logged with Autohold option selected is identified by “H” in the Notes column.*
- *Data logged with Manual option selected may have a custom name added.*
- *Data logged with Automatic option selected have **_auto** in the name.*

Sampling Period

Options: 1, 2, 5, 10, 30 sec., 1, 2, 5, 10, 15, 30, 60, 120, 150, 180 min.

Option available with **Automatic** logging type only.

Time-interval option is from scrollable list.

File Name

Option available with **Manual** and **Autohold** logging type only.

To create a file name, from Logging screen:

1. Tap **Create**.
2. Use the keypad and enter file name (maximum 13 characters).
3. Tap  to confirm.

Log Note & Log Info

Notes on measured data are saved together with logged data.

Sample ID

Manual and autohold samples can be labeled with a text label and a numerical ID.

With **Increment** selected:

1. Tap **Sample ID Prefix**.
2. Use the on-screen keypad to enter a text prefix to the sample name (maximum 15 characters).
3. Tap  to confirm.
4. Select ID number from scrollable list.

The ID number will increment with each new sample logged.

With **Manual** selected:

1. Tap **Sample ID Prefix**.
2. Use the on-screen keypad to enter a text prefix to the sample name (maximum 15 characters).
3. Tap  to confirm.

When the measurement is logged, a pop up is displayed and the sample ID can be modified.

9.7. PROFILES

A profile is a sensor setup complete with required measurement unit, temperature unit, display preference, and alarm threshold options.

Once saved the profile can be loaded for applications that require similar configurations.

Saved profiles are only accessible by the user who created it.

Select **Profiles** tab to configure measurement profiles.

Profile Feature

Tap to enable or tap to disable the option.

With option enabled, profile operations are active.

The default profile is always available with the factory settings.

After any modification to Calibration, Reading, Temperature, View, or Alarms tabs, the name of the current profile is indicated with **(Modified)***.

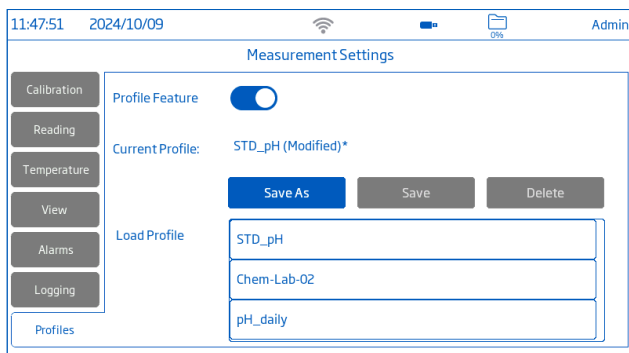

The profile name is displayed next to the  icon (Profile icon).

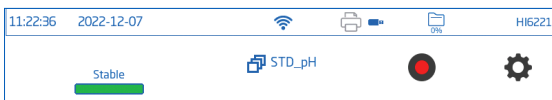

To save a profile, having previously configured all other application-specific options from the measurement settings:

1. Tap **Profiles** tab.
2. Tap **Save As** and use the keypad to enter profile name. (maximum 20 characters).
3. Tap  to confirm.

Once saved, profile name is added to the Load Profile list.

Load Profile

- Tap to select a configured profile from the **Load Profile** list.
- Profile name is automatically entered in the **Current Profile** field.

10. CALIBRATION PROCEDURE

10.1. pH CALIBRATION

Calibration Guidelines

- Set up a routine service schedule where measurement integrity is validated.
- Do not handle the sensing surfaces of the sensors.
- Avoid rough handling and abrasive environments that can scratch the reactive surfaces of the sensors.
- For best technique, use a rinse beaker and a separate calibration beaker for each buffer.
- Do not return the used buffers to the bottles of “fresh” buffer.
Discard buffers after use.
- For measurements across a temperature gradient (when water temperature is drastically different from the buffers), allow the electrodes to reach thermal equilibrium before conducting calibrations or making measurements.
- During calibration the temperature probe should be in the calibration buffer.

Buffer Group (Automatic Calibration Only)

In addition to selecting from 8 standard options, users can define 5 custom buffers to be used for calibration. [HI6221](#) automatically recognizes the closest buffer to the pH value being measured from all available (standard and custom) buffers.



To move buffers from **Available Standard Buffers (Available Custom Buffers)** trays to **Buffers in Use** trays:

1. Tap .
2. Tap **Calibration** tab.
3. Tap **Edit**.
4. Tap to select from the Available Standard Buffers or Available Custom Buffers trays.

A rectangular outline highlights the buffer selected for transfer.

For custom values, tap an empty tray to input a new value or an existing tray to edit the buffer value.

Follow the Editing Custom Buffers Values steps.

5. Tap  to move the selected buffer in the Buffers in Use column.
-  displayed next to the buffer value, indicates calibration with standard buffer.
-  displayed next to the buffer value, indicates calibration with custom buffer.
- Repeat with up to 5 buffers.

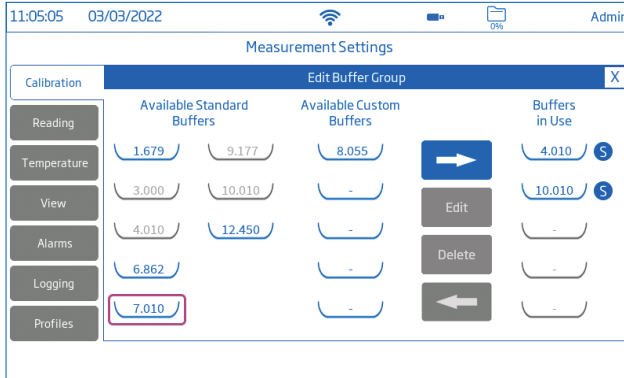

Editing Custom Buffer Values

1. Tap a custom buffer tray from the Available Custom Buffers column.
2. Tap **Edit**.

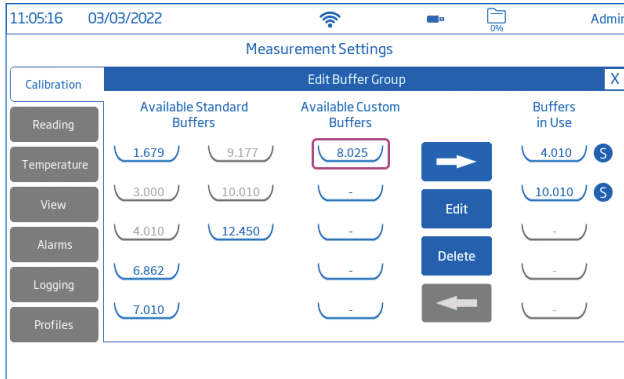

- 3. Use the numeric keypad to enter a value.
- 4. Tap  to confirm.

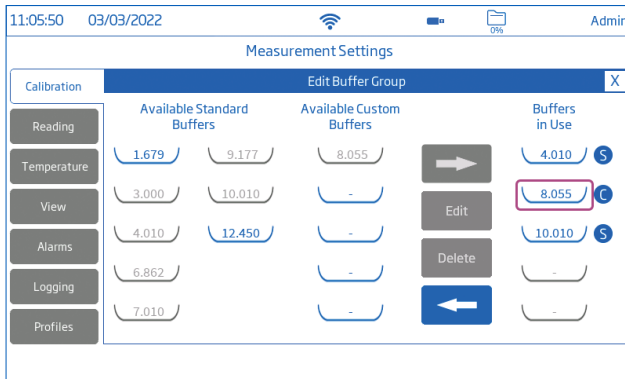
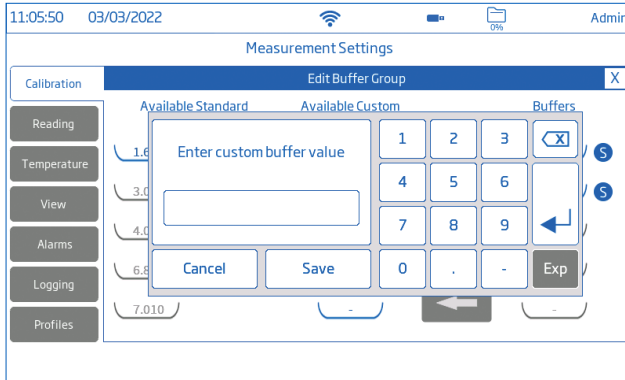

pH Calibration Procedure

With the electrode and temperature sensor connected to the meter:

1. Enter the solution temperature manually if calibration is done without a temperature sensor.
2. Remove the plastic protective cap from the probe and rinse the electrode with purified water.
3. Fill a rinse beaker 2/3 full with the first buffer solution.

For most applications it is recommended to start with pH 7.01 buffer (or pH 6.86).

Use calibration buffers that bracket the samples pH.

For acidic samples it is recommended to use pH 4.01, 3.00, and/or 1.68 buffers.

For alkaline samples it is recommended to use pH 9.18, 10.01 and/or 12.45 buffers.

4. Swirl the electrode and temperature sensor in the buffer solution.
5. Raise and lower the probe several times. Discard the solution.
6. Fill the calibration beaker 2/3 full with the first buffer solution.
7. Slowly place the electrode and temperature sensor in the selected buffer.
Dislodge bubbles that may adhere to the sensors.
8. Tap **Calibrate** and the meter will open a pH calibration screen.
9. If using a new pH electrode it is recommended to tap **Clear Calibration** to clear all buffers and start new.
10. Rinse the electrode and temperature sensor in the buffer, place in the rinse beaker then calibration beaker.

➤ **Automatic buffer entry**

The meter will automatically recognize the closest buffer to the pH value being measured from all available (standard and custom) buffers in the buffer group.

➤ **Semiautomatic buffer entry**

The meter will automatically recognize the closest buffer to the pH value being measured from all available (standard and custom) buffers.

The arrows under the beaker tray can be used to select another buffer value.

➤ **Manual buffer entry**

Use the arrows under the beaker tray to select the buffer value from all available (standard and custom) buffers.

11. Wait for the reading to stabilize and tap **Confirm Buffer** to save the calibration point and move to the next buffer.

Note: *If probe's response time is slow, clean the probe then repeat the calibration.*

Repeat procedure for a total of five calibration points.

12. Tap **Save** to update the calibration and return to the calibration screen.

Tap  key to return to measurement.

10.2. RELATIVE mV CALIBRATION

The Rel. mV calibration (or ORP calibration) allows the user to:

- Perform a single point, custom calibration (Rel. mV)
- Restore the factory calibration (Clear Calibration)

The Oxidation-Reduction Potential (ORP) displayed in mV is the voltage that results from the difference in potential between the platinum (or gold) ORP sensor and the silver/silver chloride reference electrode.

ORP values are not temperature compensated but ORP values can change with temperature e.g. reference electrode potential changes or sample equilibrium changes.

It is important to report ORP values together with the reference electrode used and the temperature.

The inert noble metal ORP surface provides an electron-exchange site with the sample (or standard) and its surface. The electron exchange is typically very fast in well-poised solutions (e.g. standards), but may be lengthier in actual samples.

Calibration establishes a baseline that can be used as a comparison for future work. Calibration is used to compensate for changes due to contamination of the platinum surface and drift in the reference electrode.

Additionally, a relative mV calibration is used to remove the voltage attributable to the Ag/AgCl reference electrode, to display the ORP versus a SHE (Standard Hydrogen Electrode). This is an arithmetic correction and is correct only at the standard temperature.

E.g.: [HI7022](#) ORP Test Solution reads 470 mV at 25 °C versus the Ag/AgCl reference.

The ORP mV versus a SHE would be 675 mV (add 205 mV to the observed value).

Note: *The user has to change the actual electrode to an ORP sensor and Parameter must be changed to Rel. mV for use with ORP electrodes. Suggested ORP models are [HI3133B](#), [HI4430B](#), or [HI3230B](#).*

See [8.3. Measurement Settings](#) for details on configuration parameters and values.

When switching between parameters (pH and mV, or Rel. mV), wait a few seconds to accommodate meter reconfiguration.

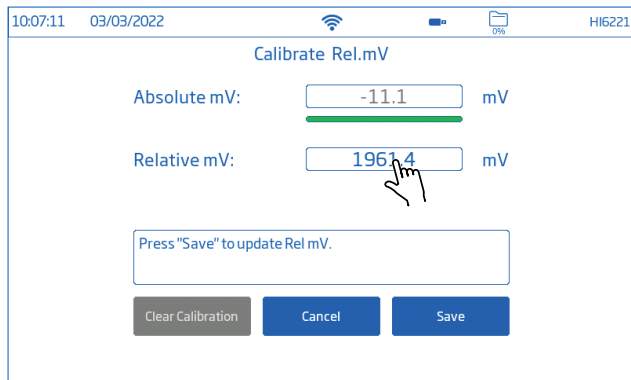

Rel. mV Calibration Procedure

1. Tap **Calibrate** and the meter will open a Rel. mV calibration screen.

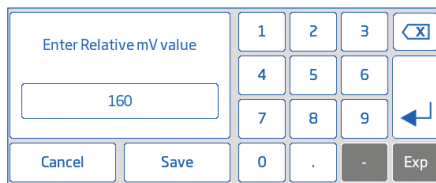

2. Place ORP electrode tip into a beaker of standard or a sample with known value. **HI7021** (ORP solution for platinum and gold electrodes) reads 240 mV at 25°C, **HI7022** (ORP test solution for platinum and gold electrodes) reads 470 mV at 25 °C.
3. Tap the Relative mV box value.



4. Tap **Clear** to remove previous values from the box.
5. Use the keypad to enter the value of the standard.
6. Tap  to confirm.
7. When a stable value is reached, tap **Save**.
The meter returns to the Rel. mV calibration screen.
8. Tap  key to return to measurement screen.

Clear calibration

1. Tap **Clear** in calibration screen.
2. The instrument prompts for confirmation.

10.3. CALIBRATION WITH MILLESIMAL BUFFERS

Hanna Instruments® manufactures millesimal buffers that are certified ± 0.002 pH. The certified values can be used during calibration.

1. Tap .
2. Tap **Reading** tab.
3. Set the resolution to 0.001 and stability criteria to Accurate.
4. Tap **Calibration** tab.
5. Tap **Edit** to edit the buffer group to include the nominal pH values for the millesimal buffers being used.
6. Following the pH Calibration Procedure section, prepare the electrode and first calibration buffer.
7. Tap **Calibrate** and the meter will open a pH calibration screen.
8. Wait for the reading to stabilize.
A box will be displayed around the recognized buffer.
9. Tap on the box to edit the buffer value.
Use the keypad to manually enter the value printed on the certificate.
Tap **Save**.
10. Tap **Confirm Buffer** to save the calibration point and move to the next buffer.
Repeat procedure for a total of up to five calibration points.
11. Tap **Save** to update the calibration and return to the measurement screen.

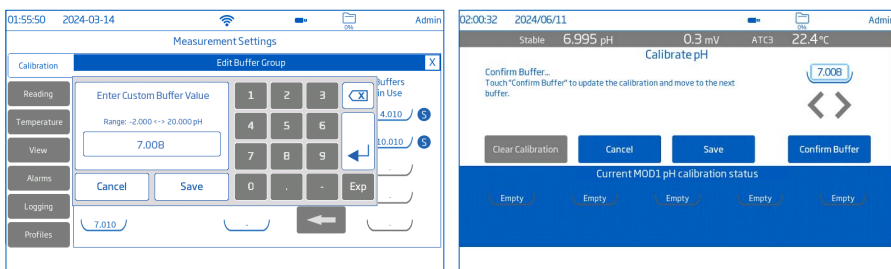

10.4. CALIBRATION MESSAGES

Check the buffer value and use fresh buffer if:

- The buffer cannot be recognized.
 - The current reading is outside of the acceptable window.
 - The current buffer is generating a slope over the of acceptable window.
 - Temperature is outside of the acceptable window.
 - The current buffer is generating a low slope.
 - The current buffer cannot be confirmed due to an inconsistency with the previous calibration.
- Additionally, clear the old calibration to continue.

Check the buffer value and choose a new buffer if:

- The current buffer has already been accepted or is too close to a buffer that has been used.

11. MEASUREMENT

Options: **Direct Readings**, **Direct/Autohold Readings**

With **Direct** mode selected, sample measurements are displayed continuously.

With **Direct/Autohold** mode selected, reading is kept on display when measurement stability is reached.

This option removes the subjective nature of stability as a measurement that has not reached equilibrium will not be used.

After stability criteria is reached, the meter enters Direct/Autohold mode.

11.1. MEASUREMENT TIPS

- Connect the electrode to be used to the appropriate meter input.
Make sure the electrode has been recently calibrated and is working correctly.
- Place electrode into the [HI764060](#) electrode holder for easy transfer in and out of containers during calibration, sample measurement, and storage.
- Rinse with purified water between buffers and / or samples.
- Blot (never rub) the glass pH sensor with a lint-free tissue between buffers and samples.
- To limit sample contamination, pour two beakers of buffers and samples.
Use one beaker to rinse the sensor and the second for measurement.
Note: *Use the same size beaker and immersion depth for samples and buffers.*
- Gently stir the test sample to ensure the sensor is measuring a representative sample.
- Open the fill hole cover and keep the fill solution topped off to permit the fill solution to flow through the ceramic junction and maintain a stable reference signal.
- If measuring across a temperature gradient, allow the sensor to reach thermal equilibrium.
- If using manual temperature compensation input the sample temperature.
- Once the reading indicates Stable, record measurement data.
- When all samples have been measured, rinse the pH electrode and replace storage cap with storage solution.
Replace fill hole cover.



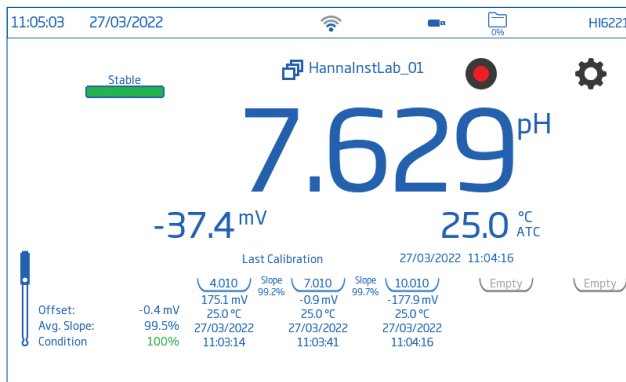

Note: *When working without a temperature sensor, ensure that both calibration and measurement are done at the same temperature. This requires manual input of temperature value to allow the meter to perform buffer temperature correction.*

11.2. DIRECT READINGS

- Place the electrode tip and the temperature probe approximately 4 cm (1.5") into the sample to be measured. Allow time for the electrode to stabilize.
-  is displayed until measurement is stabilized.
- The measured pH value is displayed on the LCD.



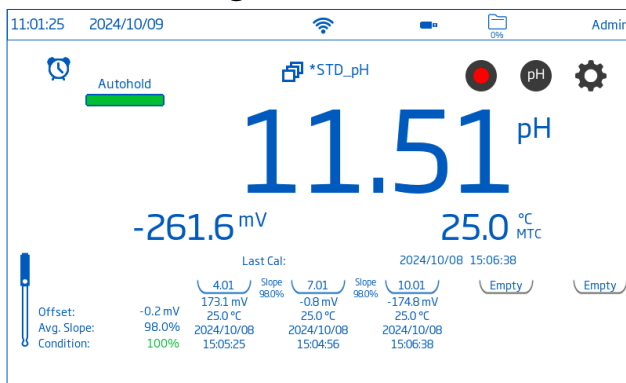

11.3. DIRECT / AUTOHOLD READINGS

- Place the electrode tip and the temperature probe approximately 4 cm (1.5") into the sample to be tested.
- Tap  to enable the autohold reading mode.
- The measured parameter value will be displayed on the LCD.
-  is displayed blinking.
- Once the stability criteria is reached, the measured value is frozen on the display.
-  stops blinking.
- To return to direct Reading Mode, tap .





12. LOGGING

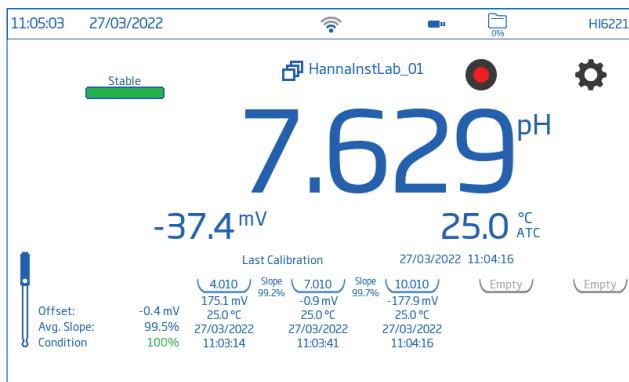

12.1. AUTOMATIC LOGGING

1. From measurement screen, tap 
2. Tap **Logging** tab and select **Automatic** logging type.
3. Scroll to select Sampling Period.
4. Log Note and Log Information can be entered.
5. Tap  to return to the measurement screen.
6. Tap  to start logging.









7. During active logging, users can add a note to the logged sample. Notes are visible in log recall and .CSV files..
 - Tap  to add note to the sample.
 - Use on-screen keypad to enter text.
 - Tap  to save entered note.
8. Tap  to stop the log.

Automatic logging with Autohold



1. Tap **Reading** tab, then select **Direct/Autohold** reading mode.
 2. Tap **Logging** tab, then select **Automatic** logging type.
 3. Tap  to return to the measurement screen.
 4. Tap  to start logging.
- All data will be added to the log at the selected sampling period.
5. Tap the  to initiate an autohold reading.

Once the stability criteria has been met, the value will be held on the screen and the  is displayed. At the selected sampling period this value will be saved to the log.





In the log file a "H" is displayed in the notes column. The reading being held on the screen, will continue to be saved at the selected sampling interval.

6. Users can add a note to the logged sample. Notes are visible in log recall and .CSV files.
 - Tap  to add a note to the sample.
 - Use on-screen keypad to enter text.
 - Tap  to save entered note.
7. Tap a parameter icon — ,  — to release the autohold reading and continue logging at the selected sampling period.
Additional autohold reading can be initiated by tapping the .
8. Tap  to stop the log.

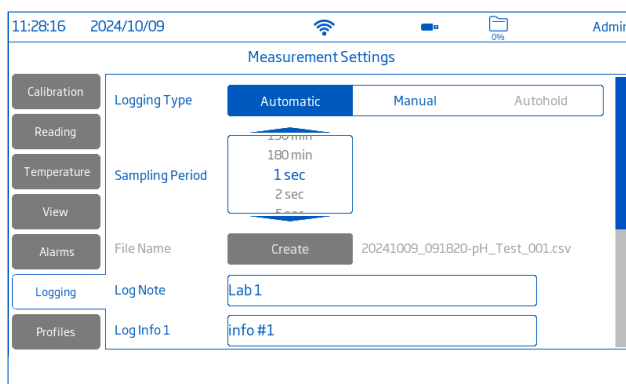



12.2. MANUAL LOGGING

1. From measurement screen, tap .
2. Tap **Logging** tab, then select **Manual** logging type.
3. Tap **Create** to enter a file name.
 - Use on-screen keypad to enter text.
 - Tap  to save entered note.



4. Tap **Increment** to set a sample name (Prefix and Sample ID).
5. Tap  to return to measurement screen.
6. Tap  to log data.
Data is logged every time symbol is tapped.
If Manual sample ID was selected, use the on-screen keypad to enter the sample ID and notes on the pop-up.
7. Users can add a note to the logged sample. Notes are visible in log recall and .CSV files.
 - Tap  to add a note to the sample.
 - Use on-screen keypad to enter text.
 - Tap  to save entered note.



Manual logging with Autohold

1. From measurement screen, tap .
2. Tap **Reading** tab and then select **Direct/Autohold** reading mode.
3. Tap **Logging** tab, then select **Manual** logging type.
4. Tap **Create** to enter a file name.
5. Tap **Increment** to set a sample name (Prefix and Sample ID).
6. Tap  to return to the measurement screen.
7. Tap  to save a reading to the log file.
8. Tap  to initiate autohold.

Once the stability criteria has been met, the value will be held on the screen and the  is displayed.

9. Tap  to save the autohold reading to the log file.

In the log file a "H" is displayed in the notes column.

10. Tap a measure parameter icon — ,  — to release the autohold reading.
Additional autohold reading can be initiated by tapping the .

12.3. AUTOHOLD LOGGING

1. From Measurement screen, tap  (Measurement Menu).
2. Tap **Reading** tab to select stability criteria.
Option to select between Accurate, Medium, or Fast.

Note: Autohold logging uses this criteria for logging. Setting this will affect when data is recorded.



3. Tap to select **Direct/Autohold** reading mode.
4. Tap **Logging** tab and select **Autohold** logging type.
5. Tap **Create** to enter a file name.
6. Tap **Increment** to set a sample name (Prefix and Sample ID).
 - Use the on-screen keypad to enter lot file name.
 - Tap  to save.
 - Scroll to select Prefix value.



7. Tap  to return to measurement screen.

8. Tap  and .

Once the stability criteria is met, the value will be held on the screen and the  is displayed.

The meter stores the data point in the log file.

9. Tap a measure parameter icon — ,  — to release the autohold reading.
Additional autohold reading can be initiated by tapping the .

10. Tap  to manually save data point to the log file.
11. Tap  to initiate a new Autohold data point.

Note: Autohold logging and Autohold are enabled together, the user will only see one log point added to the data file.

13. MAINTENANCE & CONDITIONING

13.1. METER

The following steps outline the process to ensure users keep the meter clean and disinfected while limiting the risk of damage from unsuitable cleaners.

- Disinfect the screen using commercially available, non-ammonia glass or disinfectant cleaner.
- Apply a small amount of cleaner directly to a microfiber or lint-free disposable cloth.
Make sure the cloth is damp and not wet.
- Wipe the glass touchscreen clean with the cloth.
Do not apply cleaner directly to the interface.

13.2. HI1131B pH ELECTRODE

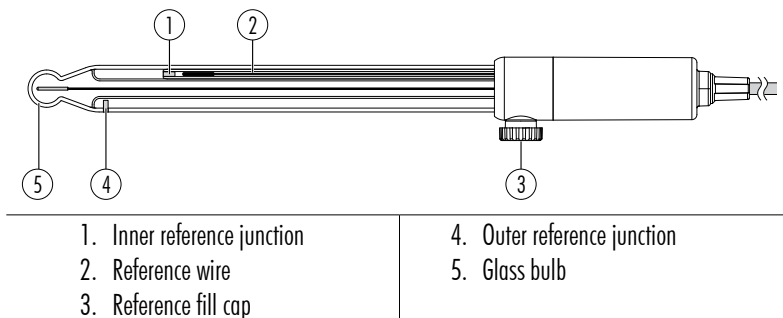

Electrode Maintenance

- Soak the pH bulb and reference junction in [HI70300](#) Storage Solution for a minimum of 30 minutes to refresh the electrode (before calibration).
- Calibrate the electrode after prolonged storage or cleaning.
- After use, rinse the electrode with purified water and blot excess moisture with a lint free tissue.
- Inspect all sensor connectors for corrosion and replace if necessary.

pH Sensor Maintenance

- Remove the sensor protective cap.
Do not be alarmed if any salt deposits are present. This is normal with pH / ORP probes and they will disappear when rinsed with water.
- Shake the probe down gently to eliminate any trapped air bubbles.
- If the bulb and/or junction are dry, soak the electrode in [HI70300](#) Storage solution for at least 30 minutes.
- To ensure a quick response, the glass bulb and the junction should be kept moist and not allowed to dry.
This can be achieved by storing the sensor with a few drops of [HI70300](#) Storage solution or pH 4.01 in the protective cap.

Note: Never use distilled or deionized water to store the electrode.

Periodic Maintenance

- Inspect the electrode for any scratches or cracks. If any are present, replace the electrode.
- Inspect the cable. The connection cable must be intact.
- Rinse off any salt deposits with water.

pH Cleaning Procedure

1. Soak the sensor in [HI7061](#) Electrode cleaning solution for general use or application-specific cleaning solution for 15 minutes.
2. Rinse with water.
3. Soak the electrode in [HI70300](#) Storage solution for at least 30 minutes, rinse with water and calibrate before using.

Protein, Inorganic, Oil, or Grease Cleaning Procedure

1. Soak the sensor in application-specific electrode cleaning solution (e.g. [HI7073](#) Protein cleaning, [HI7074](#) Inorganic cleaning for 15 minutes or [HI7077](#) Oil and Fat cleaning solution).
2. Rinse the sensor with water.

Note: After performing any of the cleaning procedures, rinse the electrode thoroughly with water and soak in [HI70300](#) Storage solution for at least 30 minutes before calibrating it.

3. Soak the electrode in [HI70300](#) Storage solution for at least 1 hour, rinse with water, and calibrate before using.

13.3. HI7662-TW TEMPERATURE PROBE

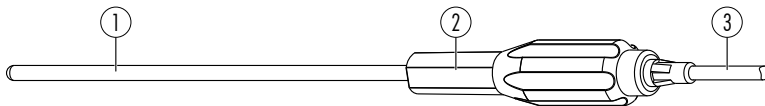

1. Stainless steel tube
2. Handle
3. Cable

14. SOFTWARE UPDATE

To introduce new features and/or performance improvements, Hanna Instruments® releases updated firmware versions. To check for new releases, scan the QR code or go to: <https://software.hannainst.com>.

Requirements

- USB-A drive (FAT32 format)



Steps

1. Scroll down the software downloads page to find the **Instrument Firmware** list.
2. Connect the USB-A drive to PC.
3. Find the Firmware Version needed for download, then click **DOWNLOAD NOW**.
4. Wait for *.hiup file download to complete.
5. Copy file to flash drive.
6. Plug the flash drive into the USB-A port and turn the meter on.



7. Wait for update to complete.
Update will take about 30 minutes to complete.
During this time do not turn off the meter or disconnect the power.



8. Once the update is complete the meter will cycle power automatically.
9. Turn off the meter and remove the flash drive.
10. Turn on the meter.

15. ERROR MESSAGES

The system gives warning messages:

- when erroneous conditions appear
- while logging
- when measured values are outside the expected range
- invalid high/low temperature alarm value
- invalid low/high mV Alarm value, isopotential point

Note: See notifications area at the bottom of the screen.

The information below provides an explanation of the errors and warnings, and recommended action to be taken.

Displayed Message	Explanation & Recommended Action
"Temperature under/over range"	Temperature outside specified range. Verify the temperature probe is correctly connected to the meter. Replace probe if necessary.
"Under/over compensation range"	During pH calibration, the temperature is under/over the pH buffer compensation limit.
"pH over range"	Occurs when apparent pH value is more than 20.0 pH. Soak electrode in HI70300 Storage solution for at least 30 minutes.
"pH under range"	Occurs when apparent pH value is less than -2.0 pH. Soak electrode in HI70300 Storage solution for at least 30 minutes.
"pH out of calibration range"	Displayed when the measured value is outside calibration range.
"Rel. mV offset over/under range"	Outside range in the corresponding scale.
"mV under/over range"	
"Factory calibration expired"	Contact the Hanna® technical support for the periodic factory calibration.

16. ACCESSORIES

pH BUFFER CALIBRATION SOLUTIONS

HI6016	Millesimal calibration buffer pH 1.679 (500 mL)
HI6003	Millesimal calibration buffer pH 3.000 (500 mL)
HI6004	Millesimal calibration buffer pH 4.010 (500 mL)
HI6068	Millesimal calibration buffer pH 6.862 (500 mL)
HI6007	Millesimal calibration buffer pH 7.010 (500 mL)
HI6010	Millesimal calibration buffer pH 10.010 (500 mL)
HI6124	Millesimal calibration buffer pH 12.450 (500 mL)
HI8004L	Buffer solution pH 4.01 (500 mL, FDA approved bottle)
HI8006L	Buffer solution pH 6.86 (500 mL, FDA approved bottle)
HI8007L	Buffer solution pH 7.01 (500 mL, FDA approved bottle)
HI8009L	Buffer solution pH 9.18 (500 mL, FDA approved bottle)
HI8010L	Buffer solution pH 10.01 (500 mL, FDA approved bottle)

ELECTRODE ELECTROLYTE REFILL SOLUTIONS

HI7071	3.5M KCl + AgCl Electrolyte for single junction electrodes, 4 pcs. (30 mL)
HI7072	1M KNO ₃ Electrolyte, 4 pcs. (30 mL)
HI7082	3.5M KCl Electrolyte for double junction electrodes, 4 pcs. (30 mL)
HI8071	3.5M KCl + AgCl Electrolyte for single junction electrodes, 4 pcs. (30 mL, FDA approved bottle)
HI8082	3.5M KCl Electrolyte for double junction electrodes, 4 pcs. (30 mL, FDA approved bottle)
HI8093	1M KCl + AgCl Electrolyte, 4 pcs. (30 mL, FDA approved bottle)

ELECTRODE STORAGE SOLUTIONS

HI70300L	Storage solution (500 mL)
HI80300L	Storage solution (500 mL, FDA approved bottle)

ELECTRODE CLEANING SOLUTIONS

HI70000P	Electrode rinse sachet, 25 pcs. (20 mL)
HI7061L	General purpose solution (500 mL)
HI7073L	Protein cleaning solution (500 mL)
HI7074L	Inorganic substance cleaning solution (500 mL)
HI7077L	Oil and Fat cleaning solution (500 mL)
HI8061L	General purpose solution (500 mL, FDA approved bottle)
HI8073L	Protein cleaning solution (500 mL, FDA approved bottle)
HI8077L	Oil and fat cleaning solution (500 mL, FDA approved bottle)

OTHER ACCESSORIES

HI740036P	100 mL beaker (10 pcs.)
HI740037P	20 mL beaker (10 pcs.)
HI764060	Electrode holder
HI900946	115 Vac to 24 Vdc power adapter, US plug
HI900947	230 Vac to 24 Vdc power adapter, European plug
HI920016	USB type A to C cable

ELECTRODES

Electrode part numbers ending in **B** are supplied with a BNC connector and 1 m (3.3') cable.

Electrode part number ending in **Y** are supplied with a BNC + RCA connector

pH

HI1043B

Glass body, double junction, refillable, combination electrode

Application: strong acid or alkali

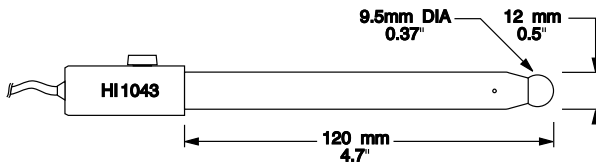

pH

HI1053B

Glass body, triple ceramic, conical shape, refillable, combination electrode
Ideally suited for emulsions.

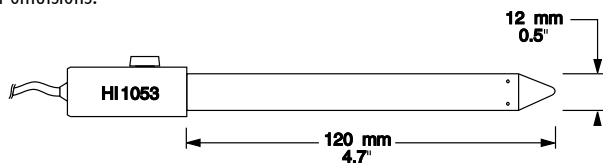
**HI1083B**

Glass body, micro, viscolene, non refillable, combination electrode
Application: biotechnology, micro titration

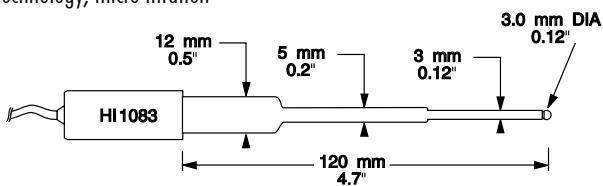
**HI1131B**

Glass body, refillable, double junction, combination electrode
Application: general purpose

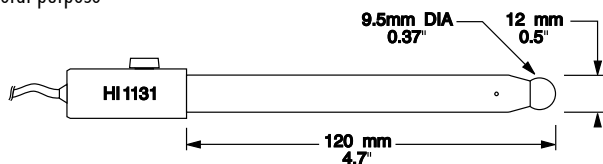
**HI1330B**

Glass body, semimicro, single junction, refillable, combination electrode
Application: laboratory, vials

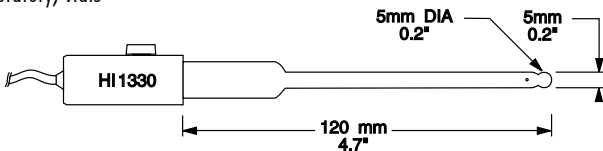

pH

HI1331B

Glass body, semimicro, single junction, refillable, combination electrode
Ideally suited for flasks.

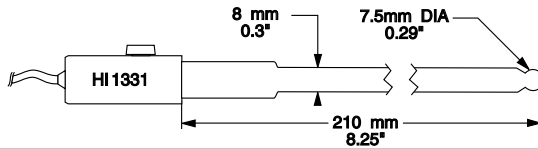
**HI1230B**

Plastic body (PEI), double junction, gel filled, combination electrode
Application: general, field

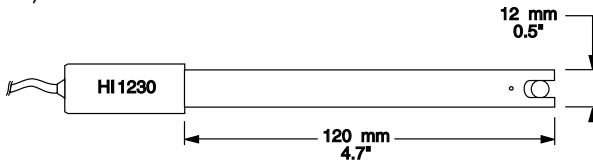
**HI2031B**

Glass body, semimicro, conical, single junction, refillable, combination electrode
Application: semisolids

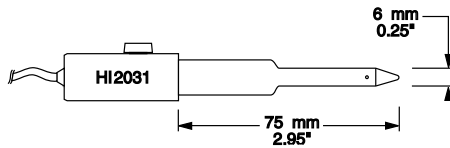
**HI1332B**

Plastic body (PEI), double junction, refillable, combination electrode
Application: general purpose

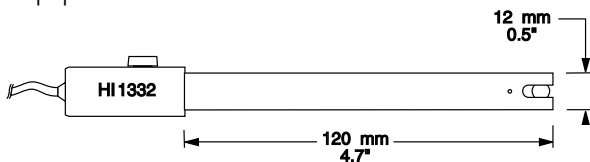
**HI1413B**

Glass body, single junction, flat tip, viscolene, non refillable, combination electrode
Application: surface measurement

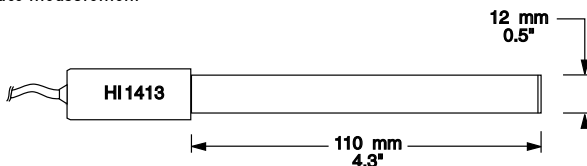

pH

FC100B

Plastic body (PVDF), double junction, refillable, combination electrode
 Application: general purpose for food industry

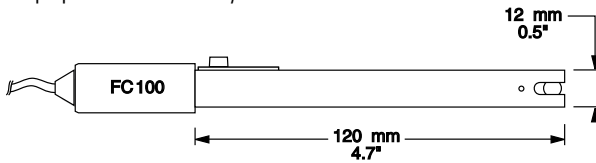

FC200B

Plastic body (PVDF), single junction, conical, viscolene, non refillable, combination electrode
 Application: meat and cheese

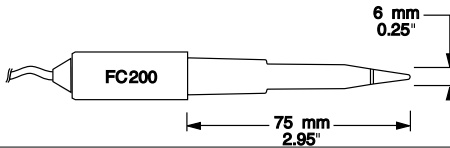

FC210B

Glass body, double junction, conical, viscolene, non refillable, combination electrode
 Application: milk and yogurt

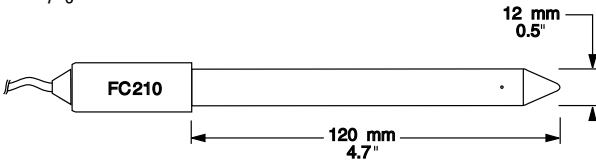

FC220B

Glass body, triple ceramic, single junction, refillable, combination electrode
 Application: food processing

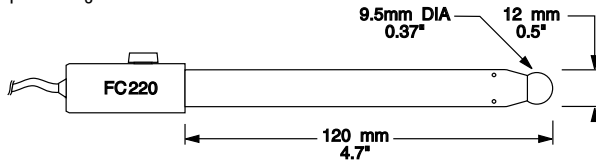

pH with 10K NTC thermistor

HI1131Y

Glass body, single ceramic frit, double junction, refillable, combination electrode

Application: general purpose

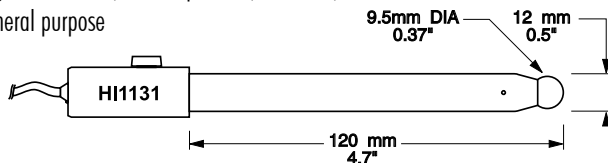

HI1230Y

PEI body, single ceramic frit, double junction, combination electrode

Application: general purpose

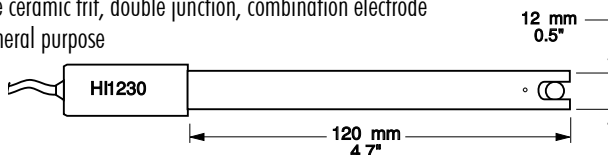

HI1048Y

Glass body, CPS sleeve junction, combination electrode

Application: wine, must, and juice

ORP

HI3131B

Glass body, refillable, combination platinum electrode, ORP sensing pin

Application: titration

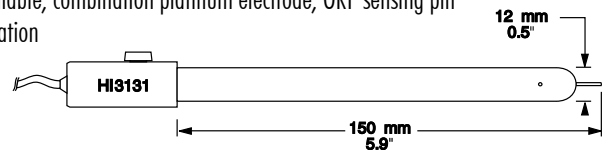

HI3230B

Plastic body (PEI), gel filled, combination platinum electrode, ORP sensing pin

Application: general purpose

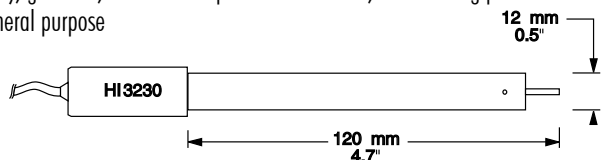

HI4430B

Plastic body (PEI), gel filled, combination gold electrode, ORP sensing pin

Application: general purpose

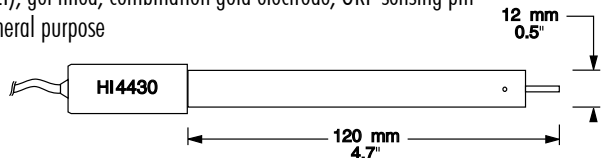

Extension cables for screw-type electrodes (screw to BNC adapter)

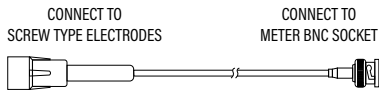

HI7855/1, 1 m (3.3') long

HI7855/3, 3 m (9.9') long

Connector and 3.0 mm (0.12") cable with BNC

Please refer to the Hanna Instruments general catalog for more electrodes with screw-type or BNC connectors.

17. ABBREVIATIONS

ATC	Automatic Temperature Compensation
CSV	Comma-Separated Values
FTP	File Transfer Protocol
GLP	Good Laboratory Practice
IIS	Internet Information Services
MTC	Manual Temperature Compensation
NIST	National Institute of Standards and Technology

CERTIFICATION

All Hanna[®] instruments conform to the CE European Directives.



Disposal of Electrical & Electronic Equipment. The product should not be treated as household waste. Instead hand it over to the appropriate collection point for the recycling of electrical and electronic equipment which will conserve natural resources.

Ensuring proper product disposal prevents potential negative consequences for the environment and human health. For more information, contact your city, your local household waste disposal service, or the place of purchase.

RECOMMENDATIONS FOR USERS

Before using this product, make sure it is entirely suitable for your specific application and for the environment in which it is used. Any variation introduced by the user to the supplied equipment may degrade the meter's performance. For yours and the meter's safety do not use or store the meter in hazardous environments.

WARRANTY

HI6221 is warranted for two years against defects in workmanship and materials when used for its intended purpose and maintained according to instructions. Electrodes and probes are warranted for a period of six months. This warranty is limited to repair or replacement free of charge. Damage due to accidents, misuse, tampering or lack of prescribed maintenance is not covered.

If service is required, contact your local Hanna Instruments office. If under warranty, report the model number, date of purchase, serial number (see engraved on the bottom of the meter) and the nature of the problem. If the repair is not covered by the warranty, you will be notified of the charges incurred. If the meter is to be returned to Hanna Instruments, first obtain a Returned Goods Authorization number from the Technical Service department and then send it with shipping costs prepaid. When shipping any meter, make sure it is properly packed for complete protection.

REGULATORY NOTICES FOR THE WI-FI MODULE**United States (FCC)** FCC ID: 2ADHKATWINC1500.

This device complies with Part 15 of the FCC Rules. Operation is subject to the following two conditions: (1) this device may not cause harmful interference, and (2) this device must accept any interference received, including interference that may cause undesired operation.

Canada (ISED) IC: 20266-WINC1500PB

HVIN: ATWINC1500-MR210PB

PMN: ATWINC1500-MR210PB

This device complies with Industry Canada's license exempt RSS standard(s). Operation is subject to the following two conditions: (1) This device may not cause interference, and (2) This device must accept any interference, including interference that may cause undesired operation of the device. Le présent appareil est conforme aux CNR d'Industrie Canada applicables aux appareils radio exempts de licence. L'exploitation est autorisée aux deux conditions suivantes: (1) l'appareil ne doit pas produire de brouillage, et (2) l'utilisateur de l'appareil doit accepter tout brouillage radioélectrique subi, même si le brouillage est susceptible d'en compromettre le fonctionnement.

Under Industry Canada regulations, this radio transmitter may only operate using an antenna of a type and maximum (or lesser) gain approved for the transmitter by Industry Canada. To reduce potential radio interference to other users, the antenna type and its gain should be so chosen that the equivalent isotropically radiated power (e.i.r.p.) is not more than that necessary for successful communication. Conformément à la réglementation d'Industrie Canada, le présent émetteur radio peut fonctionner avec une antenne d'un type et d'un gain maximal (ou inférieur) approuvé pour l'émetteur par Industrie Canada. Dans le but de réduire les risques de brouillage radioélectrique à l'intention des autres utilisateurs, il faut choisir le type d'antenne et son gain de sorte que la puissance isotrope rayonnée équivalente (p.i.r.e.) ne dépasse pas l'intensité nécessaire à l'établissement d'une communication satisfaisante.

Japan (MIC) 005-101762**South Korea (KCC)** R-CRM-mcp-WINC1510MR210P**Taiwan (NCC)** CCAN18LP0321T2

注意！依據 低功率電波輻射性電機管理辦法 第十二條 經型式認證合格之低功率射頻電機，非經許可，公司、商號或使用者均不得擅自變更頻率、加大功率或變更原設計之特性及功能。第十四條 低功率射頻電機之使用不得影響飛航安全及干擾合法通信；經發現有干擾現象時，應立即停用，並改善至無干擾時方得繼續使用。前項合法通信，指依電信規定作業之無線電信。低功率射頻電機須忍受合法通信或工業、科學及醫療用 電波輻射性 電機設備之干擾。

China (SRRC) CMIIT ID: 2018DJ1305**ANATEL** 08497-18-08759

Note: FCC information is marked on the back of the device.